

Zehnder ComfoAir 155 WMe

Wall mounted mechanical supply and extract ventilation with heat recovery (MVHR) with humidity sensor

Product data sheet

always the best climate



ComfoAir 155 WMe

The Zehnder ComfoAir 155 WMe is a heat recovery unit designed to enable better and easier specification of ventilation in new properties. It contains features such as its automatic true summer by-pass, high heat recovery efficiency and integrated humidity sensor to provide a comfortable, healthy and energy-efficient indoor climate.



Example controls - sold separately



ZGRC1 Speed controller



ZGS2 Switch



ZGS1 Switch

Key Benefits

- Left or right hand configuration through software alone, no mechanical alteration required.
- 100% full and filtered summer bypass.
- Independently tested sound data.
- Modern, discreet design.
- Easy installation to wall, cupboard or kitchen cupboard.
- Special pod wall / cupboard mounting option available, ideal for secure fixing during pod transportation.
- Light to handle.
- BMS capability.
- Tool free filter access.
- Volt free contact boost capability.
- CommissionSMART™ is a commissioning wizard that enable a quick and simple set-up process.
- SummerSMART™ ensures automatic full by-pass activation providing filtered supply air 365 days a year.
- TimerSMART™ eliminates nuisance noise and over-ventilation by determining the duration of occupancy and allocating a suitable overrun time.
- HumidiSMART™ continuously monitors the humidity level within the home and looks for a man-made spike before boosting the unit, irrespective of distance or dilution.
- 100% variable AUX speed for use as away mode, medium speed or purge boost.

Article Numbers

Description	Product Code
Unit Zehnder ComfoAir 155 WMe for wall or cupboard mounting with SMART technology	CA155WMe-GB
Zehnder ComfoAir 155 WMe for pod wall / cupboard mounting with SMART technology	CA155WMeP-GB

Controls

Controls, three position switch for ComfoAir 155/185 and Centair range	ZGS1
Controls, two position switch for ComfoAir 155/185 and Centair range	ZGS2
Controls, dual speed controller for ComfoAir 155/185 range with operational and service indicators	ZGRC1
Controls, remote air quality sensor	AQR
Controls, remote humidity sensor	HHR
Controls, remote passive infra-red movement sensor	PIRR
Controls, remote temperature sensor	THR

Filters

Filter for Zehnder ComfoAir 155 WMe, ISO Coarse (G3) , 2 Pieces	CA155FIL
Filter for Zehnder ComfoAir 155 WMe, ISO Coarse (G4) , 2 Pieces	CA155FIL.UPG

Accessories

Heat exchanger for Zehnder ComfoAir 155 WMe	CA155HFEX
First Fix Manifold for Zehnder ComfoAir 155 WM/WMe and Vireo HR155WM	CA155WMFFM

SAP PCDB

SEC Class

	SFP (W/l/s)		Efficiency (%)	
	2009	2012	2009	2012
K+1	0.45	0.50	92%	90%
K+2	0.47	0.62	90%	88%
K+3	0.56	0.80	88%	86%
K+4	0.70	1.05	87%	85%
K+5	0.85	1.31	86%	84%
K+6	1.03		85%	
K+7	1.26		84%	



Based on average climate with local demand control

Pressure Curve

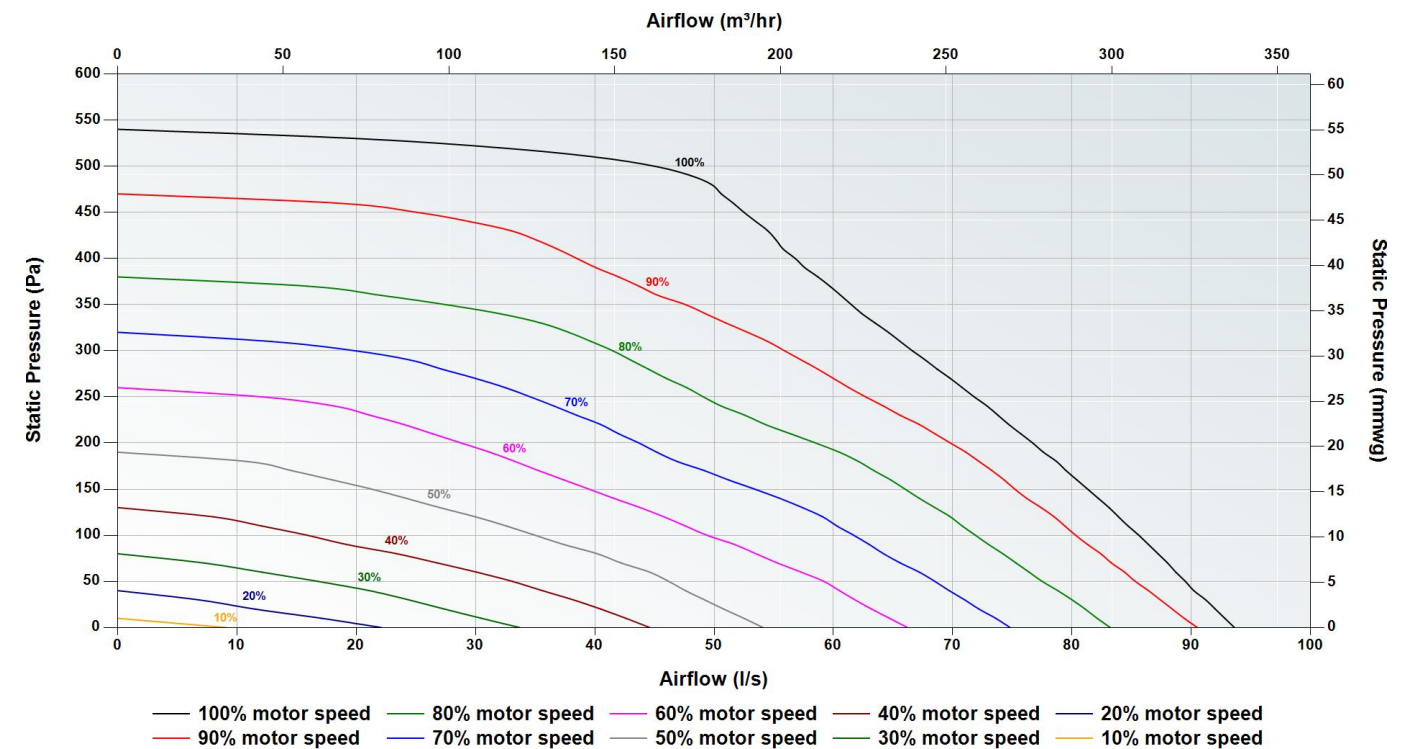

Sound Data

Speed	Test area	Octave Band (Hz) Sound Power Level, dB								dB(A) @ 3 m
		63	125	250	500	1000	2000	4000	8000	
20%	Casing	26.6	25.5	23.4	26.1	20.8	15.1	17.9	22.6	10.4
	Supply/Exhaust	47.8	40.9	33.9	33.1	26.6	16.6	17.8	22.7	
	Extract/Intake	47.0	38.6	30.7	25.6	19.7	14.2	17.7	22.6	
40%	Casing	33.6	44.0	41.0	43.2	40.4	34.6	28.8	24.4	27.0
	Supply/Exhaust	63.4	60.2	53.7	52.5	53.9	46.8	38.5	35.3	
	Extract/Intake	55.8	51.4	45.2	41.0	40.9	32.9	23.1	23.3	
60%	Casing	37.6	50.2	47.1	49.3	45.0	42.4	36.8	31.4	32.9
	Supply/Exhaust	67.6	66.4	60.1	59.8	58.9	56.0	46.6	45.9	
	Extract/Intake	54.3	57.0	51.5	46.6	45.2	39.7	29.8	27.3	
80%	Casing	40.5	53.2	49.0	51.2	46.5	44.8	39.7	34.8	35.0
	Supply/Exhaust	69.6	69.3	62.0	60.9	60.2	58.6	49.4	49.4	
	Extract/Intake	57.9	59.1	53.8	48.9	46.5	42.0	32.7	30.1	
100%	Casing	41.5	55.9	53.2	55.3	50.9	49.4	44.3	40.0	39.3
	Supply/Exhaust	71.9	72.7	65.3	64.0	62.4	61.9	53.7	54.0	
	Extract/Intake	59.0	61.5	57.8	52.4	49.1	45.9	37.2	34.9	

Tested according to [BS EN 13141-7:2010](#). Supply and Extract showing induct sound power level. Casing dB(A) @ 3 m given as hemispherical.

Technical Specification

Weight	17.5 Kg
Ducting ø	125 mm
Condensate connection ø	21.5 mm
Filter grade	Standard - ISO Coarse (G3) Optional - ISO Coarse (G4)
Materials	Internal PP/EPS External ABS
Supply voltage	230 V / single-phase / 50Hz
Maximum power consumption	165 W
Current draw	1.1 A
Fuse rating	3 amp
Specific Fan Power	0.45 W/l/s
Heat Recovery Efficiency	0.92

Dimensions

Height	644 mm
Width	546 mm
Depth	298 mm

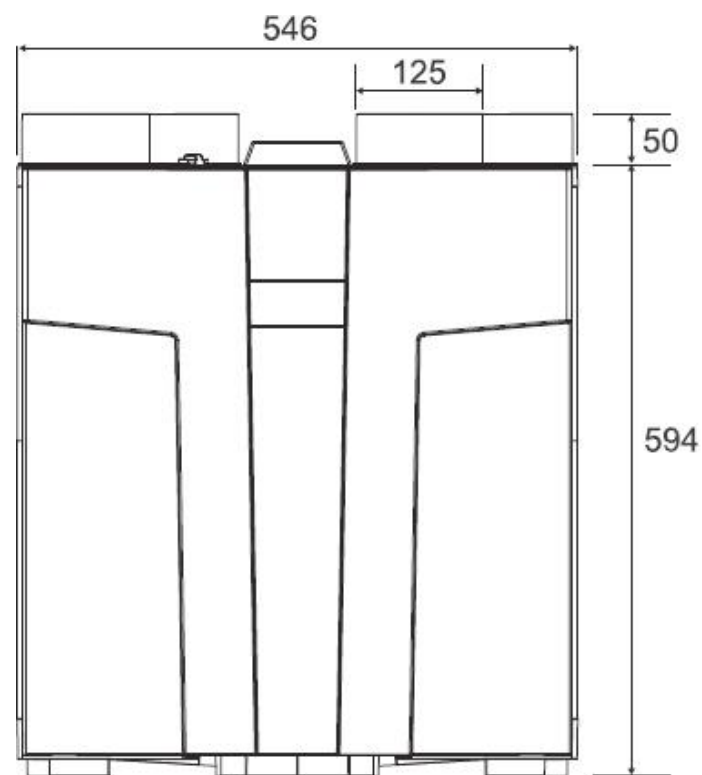

Front View

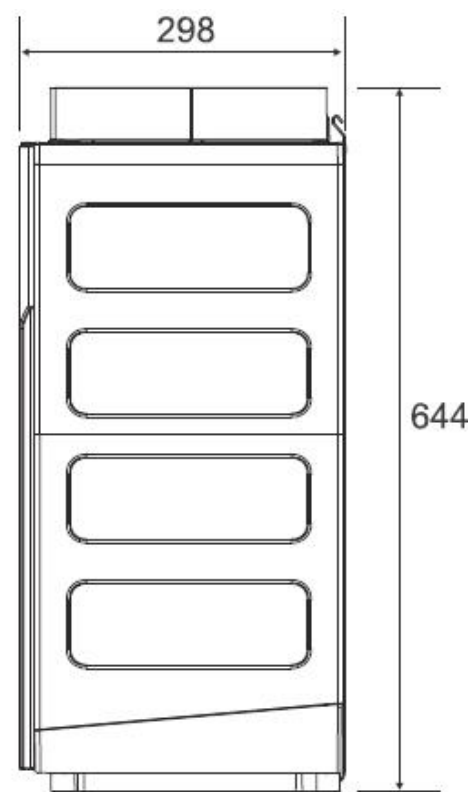

Side View

Air Direction/Connection

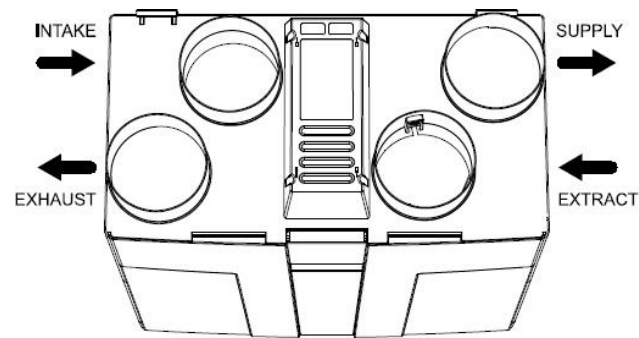

Right Hand (factory setting)

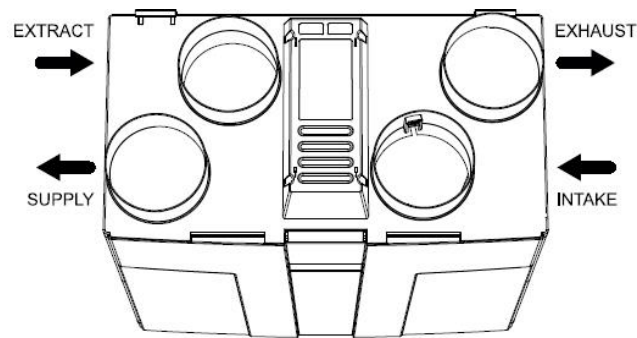

Left Hand

Wiring

Electrical connections should be carried out in accordance to IEE regulations by a qualified electrician. The unit is supplied with a flying lead for connection to the mains supply.

Three speed control via ZGS1 switch

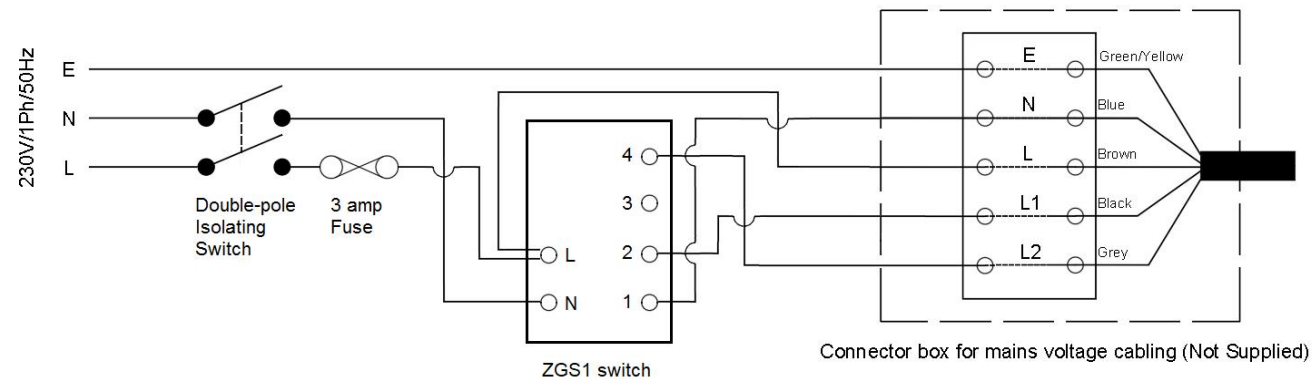

Flying lead from CA155CM-GB / CA155WM-GB / CA155WMe-GB / CA185WM-GB

Two speed control via ZGS2 switch

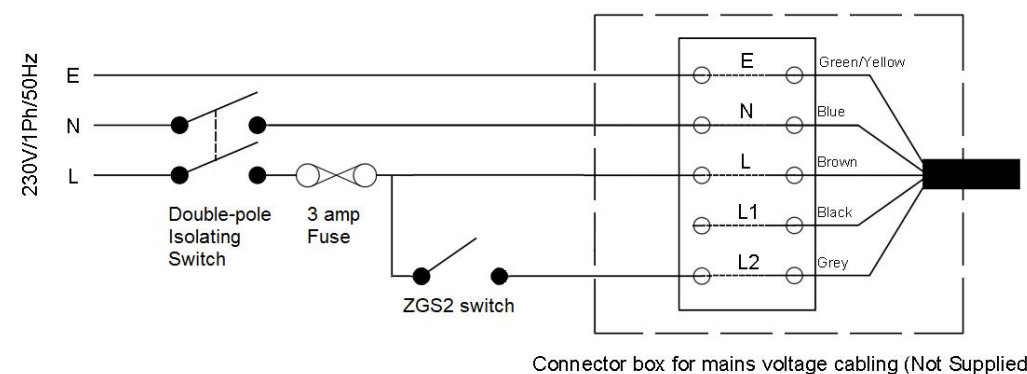

Flying lead from CA155CM-GB / CA155WM-GB / CA155WMe-GB / CA185WM-GB

Three speed control via light switch and ZGS2

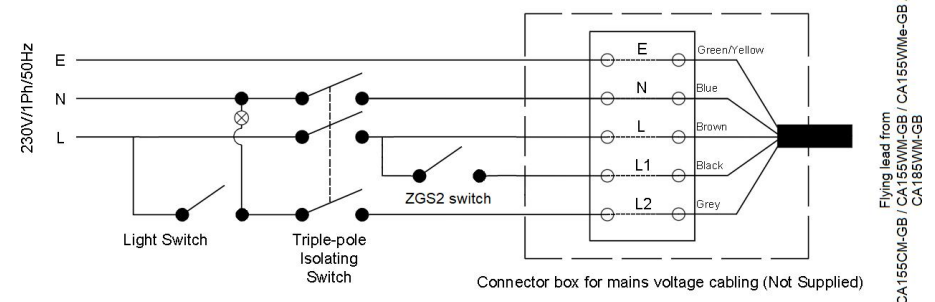

Flying lead from CA155CM-GB / CA155WM-GB / CA155WMe-GB / CA185WM-GB

Light switch (grey) = High speed
ZGS2 switch (black) = AUX speed
AUX speed to override all other speed settings

Two speed control via ZGRC1 switch

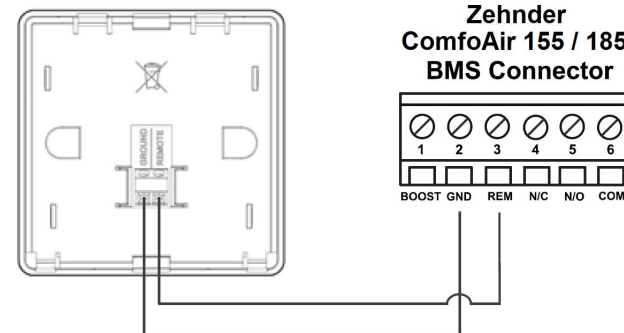

2 core cable, 0.5mm Max.
(up to 15 metres)

BMS connection

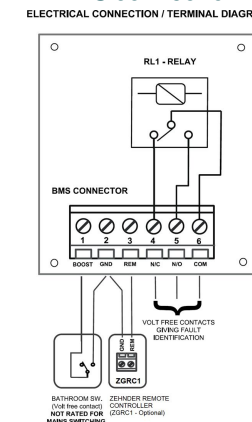

First Fix Manifold for Zehnder ComfoAir 155 WM/WMe and Vireo HR155WM

Article number: CA155WMFFM

Description

First Fix Manifold:

The first fix manifold is for use with the ComfoAir 155 WM/WMe and Vireo HR155WM heat recovery units. The manifold matches the spigot spacing for the units, making installation of the ducting from the unit to the ceiling void easier, with a high quality finish.

Technical Specification

RAL colour	RAL9003
Height	69.4 mm
Width	611.6 mm
Depth	308.4 mm
Weight	2.33 Kg
Material	Steel
Supplied with	4 x 125 mm male connectors 4 x rawlplugs 4 x pozi 8 x 1 1/2 screws 4 x m4 washers

Installation video <https://youtu.be/rgKLnAg4uwQ>



Dimensions

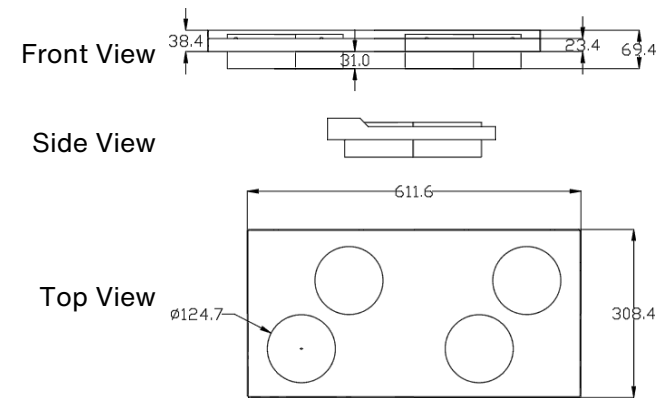

Controls

ZGS1

Product code: ZGS1



The Zehnder ZGS1 is a three position switch designed to enable the user to manually select the desired ventilation systems flow rate

Key Benefits

- 3 separate ventilation flow rate options to select in 1 controller

Technical Specification

Mounting options	Recessed
Supply voltage	Mains power - 230 V / single-phase / 50Hz

Dimensions (recessed)

Height	84 mm
Width	84 mm
Depth	22 mm

ZGS2

Product code: ZGS2

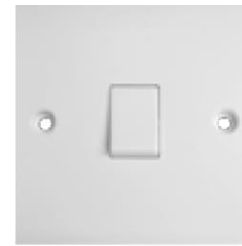

The Zehnder ZGS2 is a two position switch designed to enable the user to manually select the desired ventilation systems flow rate

Key Benefits

- 2 separate ventilation flow rate options to select in 1 controller

Technical Specification

Mounting options	Recessed
Supply voltage	Mains power - 230 V / single-phase / 50Hz

Dimensions (recessed)

Height	86 mm
Width	86 mm
Depth	15 mm

ZGRC1

Product code: ZGRC1



The Zehnder ZGRC1 is a two position switch designed to enable the user to manually select the desired ventilation systems flow rate and provide system notifications

Key Benefits

- 2 separate ventilation flow rate options to select in 1 controller
- Summer bypass indicator
- Frost protection indicator
- Service and Maintenance alert
- Automatic switching back to low speed after a pre-set time period to avoid the unit accidentally being left in its high speed

Technical Specification

Mounting options	Recessed / Surface
Supply voltage	Low voltage direct from the MVHR units BMS connector
Recommended cable	2 core cable, 0.5 mm Max. (up to 15 metres)
RAL colour	9016
Maximum number per unit	1

Dimensions (recessed)

Height	90 mm
Width	90 mm
Depth	21 mm

Dimensions (surface mounted)

Height	90 mm
Width	90 mm
Depth	37 mm

AQR

Product code: AQR



The Zehnder AQR remote air quality sensor enables a signal to be sent to the ventilation system to automatically place the unit into a higher flow rate.

Key Benefits

- Set activation level covering a range of pollutants such as hydrogen, CO, methane, ethanol and isobutane
- Adjustable overrun timer between 2-40 minutes
- Can be fitted with locking security straps to prevent tampering
- Suitable for locating where temperatures don't exceed 45°C

Technical Specification

Mounting options	Surface
Supply voltage	Mains power - 230 V / single-phase / 50Hz

Dimensions (surface mounted)

Height	86 mm
Width	93 mm
Depth	37 mm

PIRR

Product code: PIRR



The Zehnder PIRR remote passive infra-red movement sensor enables a signal to be sent to the ventilation system to automatically place the unit into a higher flow rate.

Key Benefits

- Senses movement up to 7 m away
- Adjustable overrun timer between 2-40 minutes
- Can be fitted with locking security straps to prevent tampering
- Suitable for locating where temperatures don't exceed 45°C

Technical Specification

Mounting options	Surface
Supply voltage	Mains power - 230 V / single-phase / 50Hz

Dimensions (surface mounted)

Height	86 mm
Width	93 mm
Depth	37 mm

HHR

Product code: HHR



The Zehnder HHR remote humidity sensor enables a signal to be sent to the ventilation system to automatically place the unit into a higher flow rate.

Key Benefits

- Set humidity activation between 30-90% relative humidity
- Adjustable overrun timer between 2-40 minutes
- Can be fitted with locking security straps to prevent tampering
- Suitable for locating where temperatures don't exceed 45°C

Technical Specification

Mounting options	Surface
Supply voltage	Mains power - 230 V / single-phase / 50Hz

Dimensions (surface mounted)

Height	86 mm
Width	93 mm
Depth	37 mm

THR

Product code: THR



The Zehnder THR remote temperature sensor enables a signal to be sent to the ventilation system to automatically place the unit into a higher flow rate.

Key Benefits

- Set temperature activation between 5-35°C
- Fixed 2 minute overrun timer
- Can be fitted with locking security straps to prevent tampering
- Suitable for locating where temperatures don't exceed 45°C

Technical Specification

Mounting options	Surface
Supply voltage	Mains power - 230 V / single-phase / 50Hz

Dimensions (surface mounted)

Height	86 mm
Width	93 mm
Depth	37 mm

For use with

Our range of ComfoAir MVHR units can be used in conjunction with our ComfoTube semi-rigid ductwork. The long life and sealed ductwork helps to maintain installed performance, along with reducing noise levels and system resistance.



TO VIEW OUR COMFOTUBE INFORMATION

[CLICK HERE](#)

BIM/CAD Components

If you would like to download the BIM / CAD files for this or any other of our products then please visit our BIM library.

TO VISIT OUR BIM/CAD LIBRARY

[CLICK HERE](#)

Installation Instructions

If you would like to download the installation files for this or any other of our products then please visit our download page by clicking the link below.

TO VISIT OUR DOWNLOAD PAGE

[CLICK HERE](#)

Our Informational Videos



Watch our video on how to change the Zehnder ComfoAir filters.

TO WATCH OUR VIDEO

[CLICK HERE](#)



Watch our video on how to install the ComfoAir unit with its new transport brackets.

TO WATCH OUR VIDEO

[CLICK HERE](#)

Consultant Specification

Specification

The unit shall consist of a body manufactured in recyclable ABS. The unit shall be fully insulated with EPS to maintain excellent thermal characteristics. It shall have EC low energy motors with sealed for life bearings. The fan shall have a forward curved centrifugal impeller. The heat exchanger shall be a multi-plate, counter flow design constructed from Polystyrene with laser welded joints and shall retain up to 92% of the temperature differential of outgoing air.

The unit shall contain filters manufactured from synthetic material which has been tested to a minimum of [ISO Coarse \(G3\)](#) standard with the option to upgrade to [ISO Coarse \(G4\)](#). The filters shall be pleated to reduce the pressure drop whilst increasing the time between maintenance requirement. The unit shall have 125 mm duct connections and be suitable for vertical wall mounting with the ability to allow left or right hand configuration through the unit's software alone – no mechanical reconfiguration shall be required. The unit shall be compatible with air conditioning systems as condensate can be taken from both sides of the product simultaneously.

The unit shall have 100% full summer by-pass and provide filtered supply air 365 days of the year, even under bypass conditions. The unit shall contain a temperature sensor for each air stream to ensure correct and logical operation of the bypass damper by evaluating differential as well as absolute temperature to maximise the opportunity for free cooling.

The unit shall be constructed to have a removable cover to allow full maintenance access.

The unit shall conform to LVD and EMC standards and be CE Marked in addition to having an EU compliant energy rating label (SEC) with a minimum grade of A. The unit shall conform to [UK Electrical Equipment \(Safety\) Regulations](#) and [Electromagnetic Compatibility Regulations](#) and be UKCA Marked. The unit shall be manufactured by Zehnder.

Operation

The supply and extract unit shall be a ComfoAir manufactured by Zehnder and shall be suitable to mount on a wall or in a cupboard in accordance with the specification.

The fresh filtered air from outside shall be supplied to each of the habitable rooms and pre-heated by the warm extract air from the wet areas, such as kitchen or bathroom, via the plastic counter flow heat exchanger. The unit shall vary its speed of the EC motors automatically when it receives a signal from one of the inbuilt sensors or via external switches.

The unit shall have the ability to adjust and commission the supply and extract motors independently via the front mounted in-built LCD interface. The motors shall both offer 100% variable speed control.

Controls

All ComfoAir 155/185 units shall contain the following functions within the unit pre-wired and factory fitted by the manufacturer:

- 100% variable supply and extract motor control
- Variable low and high speed flow rate set point
- BMS compatibility offering speed control and status indication
- Switched live input
- Volt free contact
- Automatic filtered summer bypass with timed manual override option
- Heat exchanger frost protection
- Commissioning wizard to enable commissioning of the unit in just 8 simple steps
- Integral service, fault and operation indicators
- Control panel PIN protection
- Tool free filter access
- Runtime counter
- Humidity sensors to operate the unit in response to humidity spikes above natural background humidity levels as opposed to a single threshold humidity point to activate the high set point
- Variable overrun timer relative to high speed activation period
- 100% variable 3rd "AUX" speed for use as away mode, medium speed or purge boost activated via switched live input