

VORT HR 250 NETI AND VORT HR 350 AVEL HEAT RECOVERY UNITS

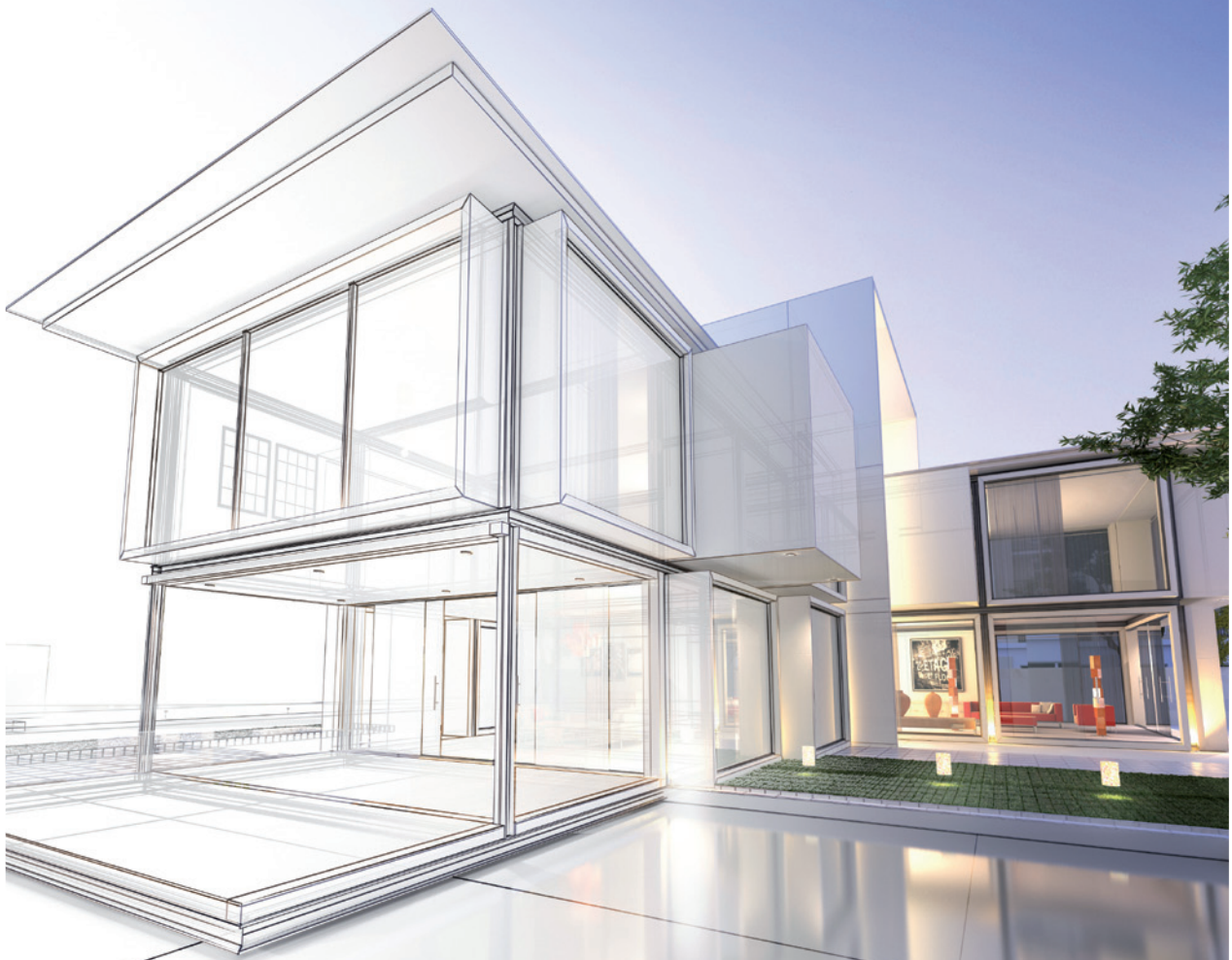

IMPORTANCE OF VENTILATION

WHY IS IT SO IMPORTANT TO VENTILATE?

It is this simplethe air we breathe is very important!

WHY IS AIR SO IMPORTANT?

- Average person spends 90% of time indoors
- Newer houses have become more air tight which means it is harder to get a fresh air path through the building
- Breathing in stale contaminated air can lead to health issues

CONDENSATION

- The appearance of condensation on the inside of windows is a frequent and annoying occurrence
- If ventilation is not correctly designed and installed then condensation levels could increase

MOULD GROWTH

- Prolonged high levels of humidity and condensation are the main cause of mould growth
- Mould spores travel through the air and multiply in wet damp areas

HEAT RECOVERY EXPLAINED

As houses become more airtight through efficiency measures a lack of natural ventilation means moisture and pollutants from every day activities remain in the home

MVHR constantly ventilates a property and recovers heat and cooling which would have otherwise been lost.

MVHR systems have the following advantages:

- Controlled air flows and air paths through the home suitable for the size and type of dwelling
- Reducing infiltration of external noise due to the removal of trickle vents
- Helps reduce the heating costs within the dwelling by recovering a high percentage of the heat/cooling that would have otherwise have been lost
- Reduction of external pollutants due to full filtration of the ventilation system.

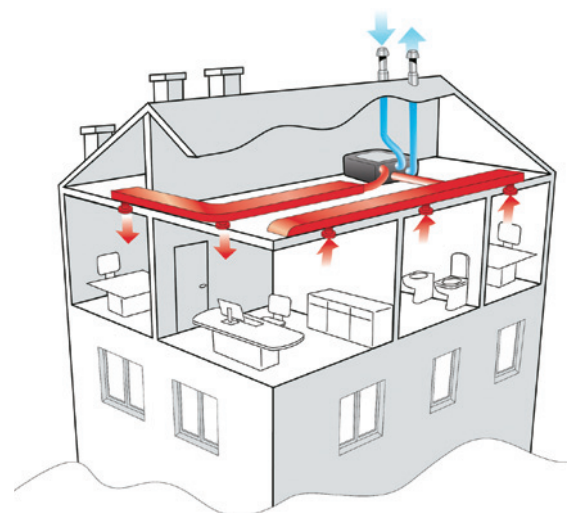

VORT HR 250 NETI VORT HR 350 AVEL

Heat Recovery units with 100% summer bypass



VORT HR 250 NETI



VORT HR 350 AVEL



KEY FEATURES

- Fresh air is **100% fully filtered** even in bypass mode which helps to maintain good indoor air quality
- Centralised mechanical extract unit with heat recovery
- Quiet Operation
- Products Characteristics Database Listed (PCDB)
- Filters included (Neti= 1 x G4 + 1 x M5, Avel= 2 x G3)
- Summer Bypass and Frost Protection
- Neti Kitchen + 5 wet rooms
- Avel Kitchen + 7 wet rooms
- Removable hinged door for easy maintenance
- Wired electronic controller with LCD panel which displays unit status
- IPX2 Rated



TECHNICAL DATA

Models	Code	V ~ 50	W	A	Max Airflow		Max Pressure		Max °C	Kg
					m³/h min/max	l/s min/max	mmH ₂ O	Pa		
VORT HR 250 NETI	11933	230	95	0.75	220	61	54	530	40	17
VORT HR 350 AVEL	11296	230	165	1.4	390	108	70	690	50	22

PCDB DATA

VORT HR 250 NETI

K+N WET ROOMS	SFP (W/I/S) [2009]	EFFICIENCY (%) [2009]	SFP (W/I/S) [2012]	EFFICIENCY (%) [2012]
n=1	0.58	88%	0.60	88%
n=2	0.58	88%	0.72	88%
n=3	0.66	86%	0.86	84%
n=4	0.80	84%	1.12	83%
n=5	0.93	84%	-	-
n=6	1.11	83%	-	-

VORT HR 350 AVEL

K+N WET ROOMS	SFP (W/I/S) [2009]	EFFICIENCY (%) [2009]	SFP (W/I/S) [2012]	EFFICIENCY (%) [2012]
n=1	0.61	91%	0.60	91%
n=2	0.56	91%	0.63	90%
n=3	0.56	90%	0.72	89%
n=4	0.65	90%	0.88	89%
n=5	0.72	89%	1.05	88%
n=6	0.85	89%	1.31	88%
n=7	0.99	88%	1.58	88%

SOUND LEVELS

VORT HR 250 NETI RPM		Sound Pressure Lp dB (A)**
K+1 (SAP2009)	Breakout	16.1
	Supply to internal	n.a
	Extract from internal	n.a
K+3 (SAP2009)	Breakout	23.7
	Supply to internal	6.9
	Extract from internal	2.4
K+6 (SAP2009)	Breakout	35.9
	Supply to internal	18.7
	Extract from internal	14.7

VORT HR 350 AVEL RPM		Sound Pressure Lp dB (A)**
K+1 (SAP2009)	Breakout	10.5
	Supply to internal	13.0
	Extract from Internal	2.7
K+3 (SAP2009)	Breakout	20.1
	Supply to internal	22.8
	Extract from internal	11.8
K+7 (SAP2009)	Breakout	32.4
	Supply to internal	35.7
	Extract from internal	23.4

Tests carried out according EN96614 standard. **Sound pressure calculated at 3m distance in free field

PERFORMANCE CURVES

VORT HR 250 NETI

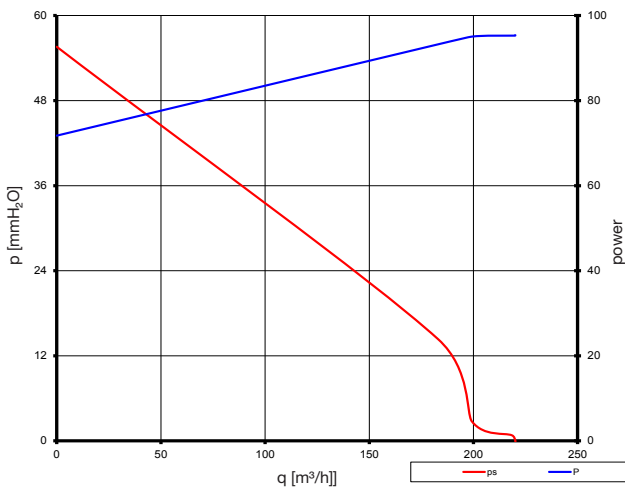

VORT HR 350 AVEL

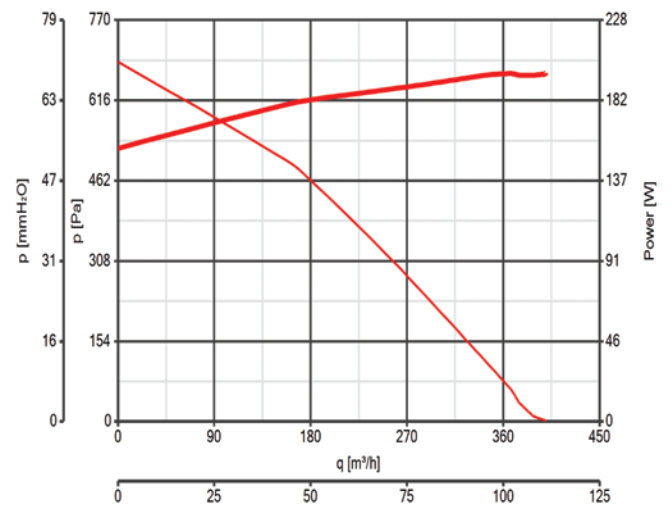

DIMENSIONS

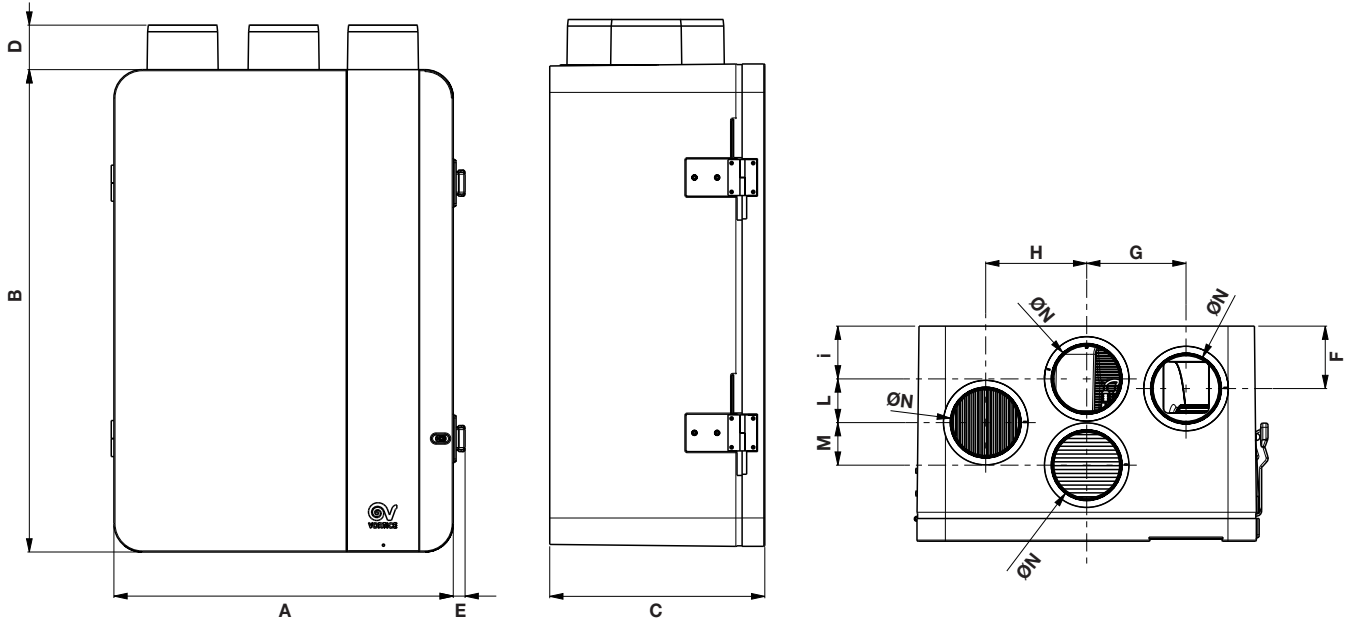

Models	Code	A	B	C	D	E	F	G	H	I	L	M	Ø N
VORT HR 250 NETI	11933	598	850	380	80	21	110	175	178	93	77	75	125

Dimensions (mm)

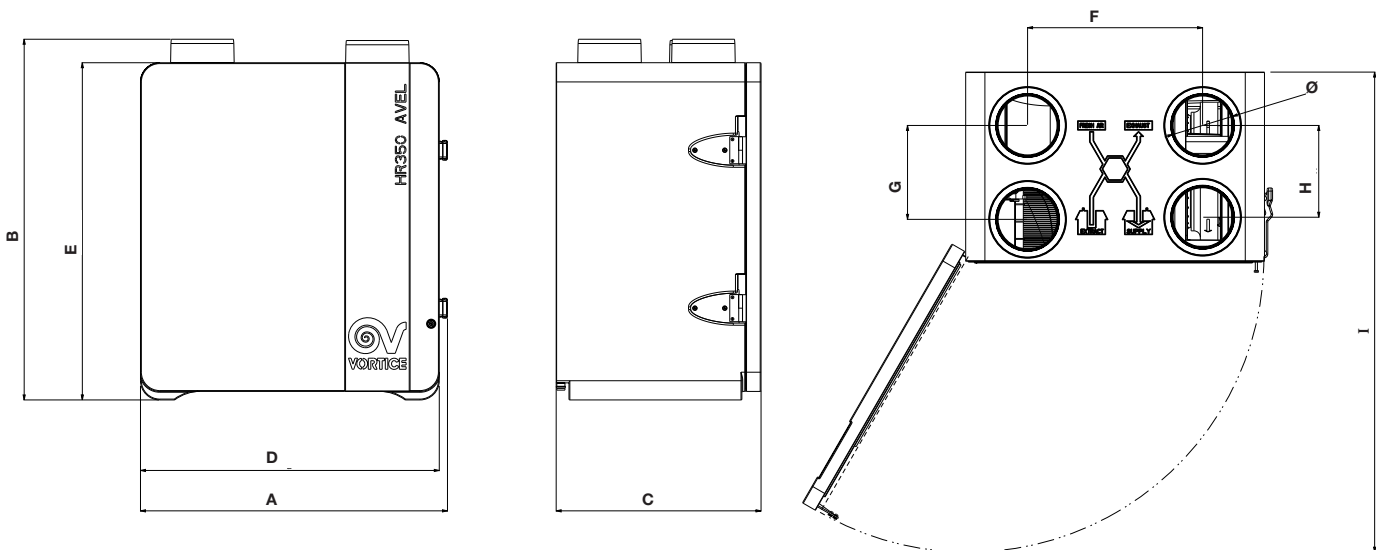

Models	Code	A	B	C	Ø	D	E	F	G	H	I
VORT HR 350 AVEL	11296	719	845	480	150	700	790	410	220	215	1130

Dimensions (mm)

ACCESSORIES

MAINTENANCE FILTERS

The filters within the unit which are easily accessible require regular periodic cleaning and replacement to allow maximum benefit of the system. We recommend the filters are inspected and cleaned every 50/60 days and replaced every 12 months. These timescales may need to be adjusted dependent on local environmental conditions.

EXTERNAL FILTER BOX

In cases where regular maintenance is not possible or desired optional external filters by means of a filter box (x2 required) can be used allowing annual replacement.

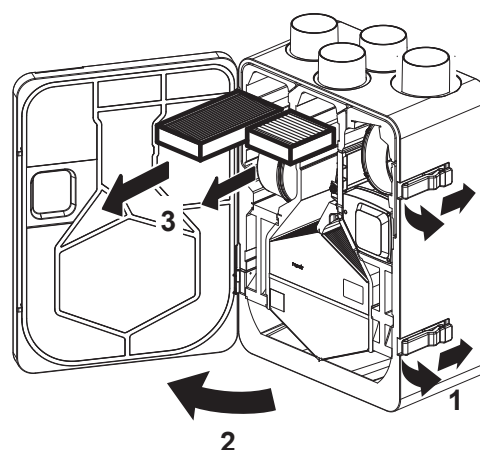

DESCRIPTION	CODE	SUITS PRODUCT
G4 Neti Filter	21116	11933
M5 Neti Filter	21117	11933
G3 Avel Filter	22661	11296
M5 Avel Filter	22662	11296
F7 Avel Filter	22664	11296
F5 External Filter Box	22329	11933 11296
F5 Filter for Filter Box	22342	11933 11296
1 Gang 1 way switch marked boost	46426	11933 11296



BPC Ventilation Ltd
8 Redlands Road
Larne
BT40 1AX

T: 028 2827 5150

E: info@bpcventilation.com

W: www.bpcventilation.com

Cod. 5.170.084.995UK

4/16

Vortice Elettrosociali S.p.A
Strada Cerca, 2
Frazione di Zoate
20067 Tribiano (Milano)
Tel. (+39) 02 906991
Fax (+39) 02 90699314
Italia
www.vortice.com
export@vortice-italy.com

Vortice France
15-33, Rue Le Corbusier
CS 30007
94046 Créteil Cedex
Tél. (+33) 1.55.12.50.00
Fax (+33) 1.55.12.50.01
France
www.vortice-france.com
contact@vortice-france.com

Vortice Limited
Beeches House, Eastern Avenue
Burton upon Trent
DE13 0BB
United Kingdom
Tel. 01283 492949
Fax 01283 544121
www.vortice.ltd.uk
sales@vortice.ltd.uk

