

Zehnder ComfoAir 350

Wall mounted mechanical supply and extract ventilation with heat recovery (MVHR)

Product data sheet

always the best climate



ComfoAir 350

The Zehnder ComfoAir 350 is a heat recovery unit designed to enable better and easier specification of ventilation in new properties due to its versatile duct connections. It can be wall or floor mounted and has rotatable spigots to duct vertically or horizontally. It contains features such as its automatic true summer by-pass, high heat recovery efficiency and upgradable high grade filters providing a comfortable, healthy and energy-efficient indoor climate.



Example controls - sold separately



ComfoControl Basic ComfoControl Basic LED

Key Benefits

- 100% full and filtered summer bypass.
- Rotatable spigots for horizontal or vertical duct connections.
- Tool free filter access.
- Volt free contact boost capability.
- ISO Coarse (G4), ISO ePM10 (M5) and ISO ePM1 (F7) filter options.
- Enthalpy cube option.
- Passive House certified.

Article Numbers

Description	Product Code
Unit	
Zehnder ComfoAir 350, left handed	CA350L
Zehnder ComfoAir 350, right handed	CA350R
Controls	
Controls, three position switch for ComfoAir standard models (CCB)	659 000 120
Controls, three position switch with service indicator for ComfoAir standard models (CCBL)	659 000 300
Zehnder RF-PCB to offer wireless connectivity to the CCRFZ without the use of a ComfoSense 67	655 000 770
Controls, remote air quality sensor	AQR
Controls, remote humidity sensor	HHR
Controls, remote passive infra-red movement sensor	PIRR
Controls, remote temperature sensor	THR
Support Frame	
Zehnder ComfoAir 350 support frame, height 300 mm	642 300 135
Filters	
Filter for Zehnder ComfoAir 350, ISO Coarse (G4), 2 Pieces	400 100 085
Filter for Zehnder ComfoAir 350/550, ISO Coarse / ISO ePM10 (G4/M5), 2 Pieces	400 102 097
Filter for Zehnder ComfoAir 350, ISO Coarse / ISO ePM1 (G4 / F7), 2 Pieces	400 100 084
Filter for Zehnder ComfoAir 350, ISO ePM1 (F7), 2 Pieces	400 100 086
Accessories	
Heat exchanger for Zehnder ComfoAir 350	400 400 010
Enthalpy exchanger for Zehnder ComfoAir 350	400 400 013

SAP PCDB

SEC Class

	SFP (W/l/s)		Efficiency (%)	
	2009	2012	2009	2012
K+1	0.77	0.71	88%	88%
K+2	0.70	0.71	88%	88%
K+3	0.69	0.80	88%	87%
K+4	0.72	0.93	87%	86%
K+5	0.79	1.07	87%	86%
K+6	0.88	1.23	86%	85%
K+7	1.00		86%	



Based on average climate with local demand control

Passive House Certification

	Standard heat exchanger
Air flow range	71–293 m ³ /h
Heat recovery rate	HR = 84%
Specific electric power	Pel,spec = 0.29 Wh/m ³



Pressure Curve

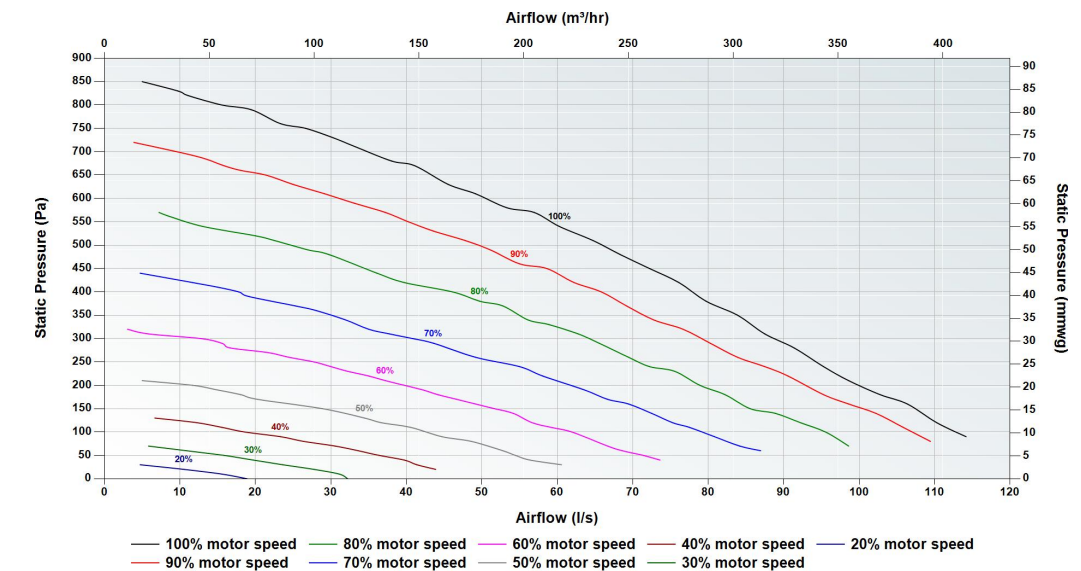

Sound Data

Speed	Test area	Octave Band (Hz) Sound Power Level, dB								dB(A) @ 3 m
		63	125	250	500	1000	2000	4000	8000	
20%	Casing		27.4	16.5	17.8	14.5	13.0			2.6
	Supply	57.2	48.0	39.6	28.0	17.8	4.5	5.0	12.2	
	Extract	63.5	49.8	33.6	23.3	19.0	10.4	7.1	11.8	
40%	Casing		35.9	37.2	33.3	30.7	28.7			18.5
	Supply	65.2	59.6	58.9	49.0	43.0	34.5	25.0	11.8	
	Extract	66.1	52.8	49.3	35.5	28.3	21.9	10.3	10.6	
60%	Casing		45.7	44.0	44.4	42.7	41.6			29.9
	Supply	68.2	70.5	68.4	61.7	56.0	48.8	41.6	29.4	
	Extract	66.0	57.3	56.4	50.8	38.9	34.1	24.8	13.2	
80%	Casing		51.0	49.2	52.3	50.4	49.4			37.6
	Supply	72.2	76.0	73.0	68.8	63.9	57.2	51.2	39.0	
	Extract	67.6	62.6	61.0	57.0	45.9	41.5	33.2	23.1	
100%	Casing		52.3	52.5	55.2	54.6	53.6			41.4
	Supply	75.5	78.5	76.0	73.5	69.4	62.4	56.9	44.9	
	Extract	72.2	65.1	64.8	60.8	50.3	45.7	38.0	29.9	

Casing tested according to ISO 3741:2010. Supply and Extract tested according to ISO 5135:1997 showing induct sound power level corrected for end duct reflection according EN 13053:2019. Casing dB(A) @ 3 m given as hemispherical.

Technical Specification

Weight	39 Kg
Ducting ø	Internal - 151 mm External - 180 mm
Condensate connection ø	32 mm
Filter grade	Standard - ISO Coarse / ISO Coarse (G4 / G4) Optional - ISO Coarse / ISO ePM1 (G4 / F7)
Materials	Internal EPP / ABS External coated sheet steel
Supply voltage	230 V / single-phase / 50Hz
Maximum power consumption	243 W
Current draw	1.77 A
Fuse rating	3 amp
Specific Fan Power	0.69 W/l/s
Heat Recovery Efficiency	0.88

Dimensions

Height	851 mm
Width	625 mm
Depth	572 mm

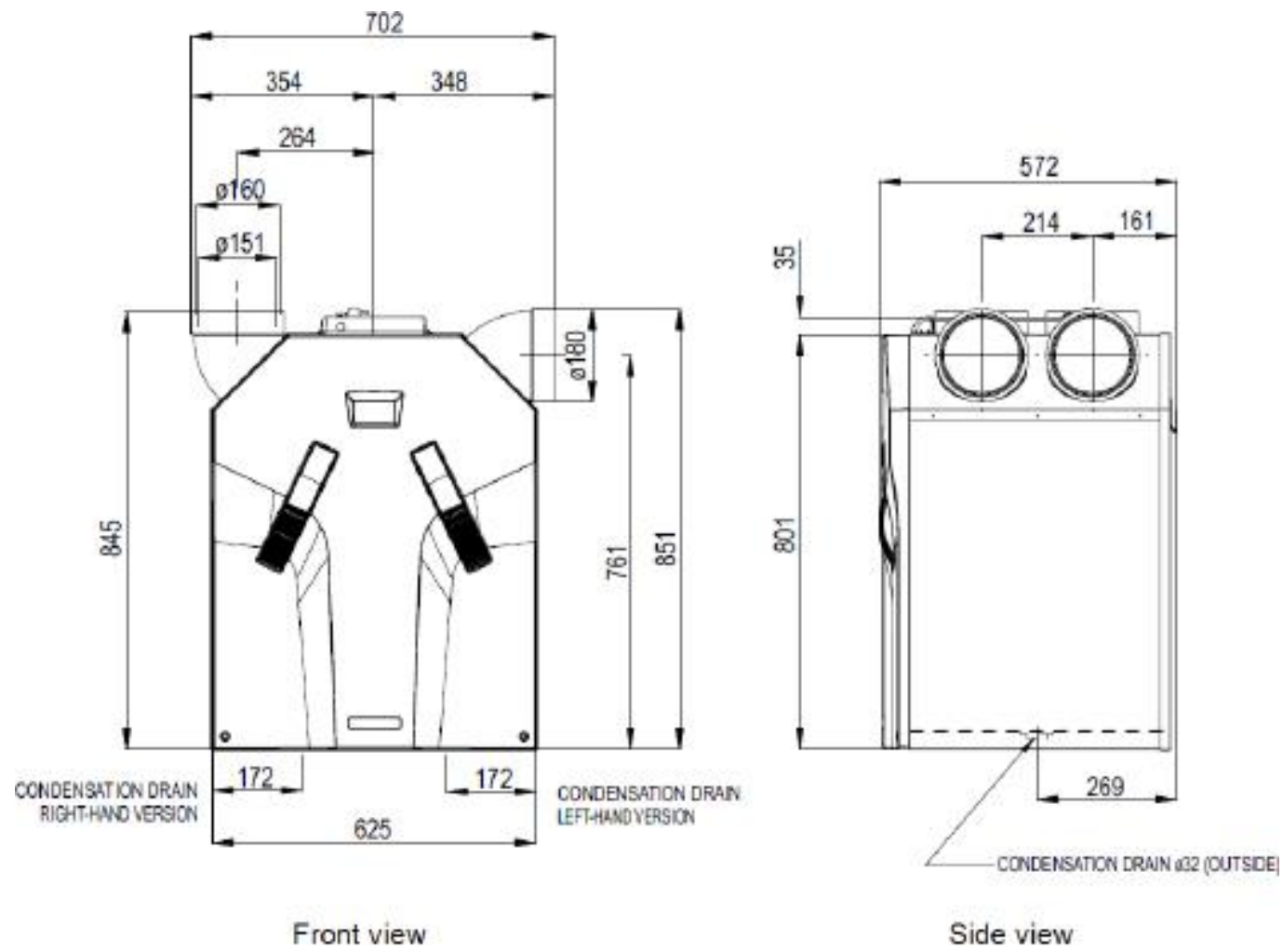

Air Direction/Connection

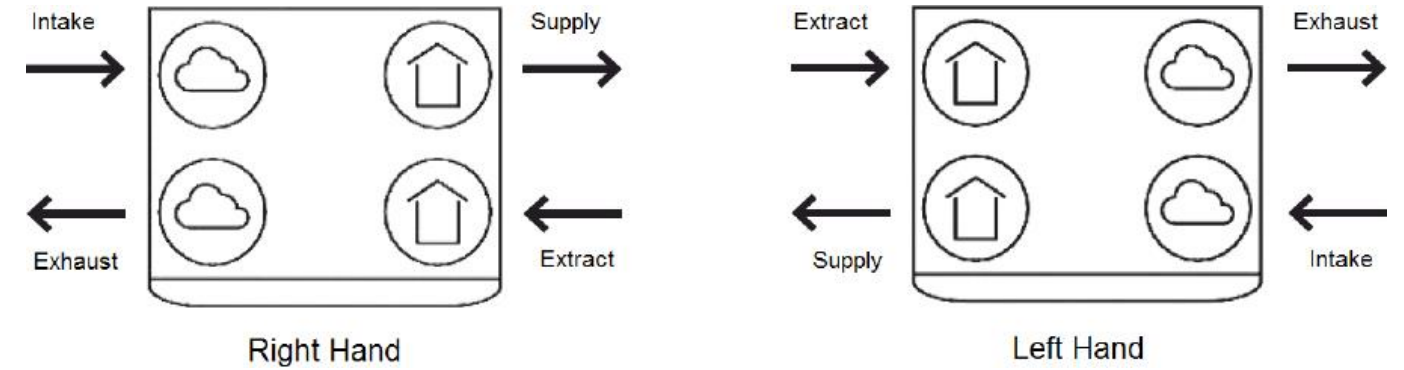

Wiring

Electrical connections should be carried out in accordance to [IEE regulations](#) by a qualified electrician. The unit is supplied with a flying lead for connection to the mains supply.

Three speed control via CCBL switch

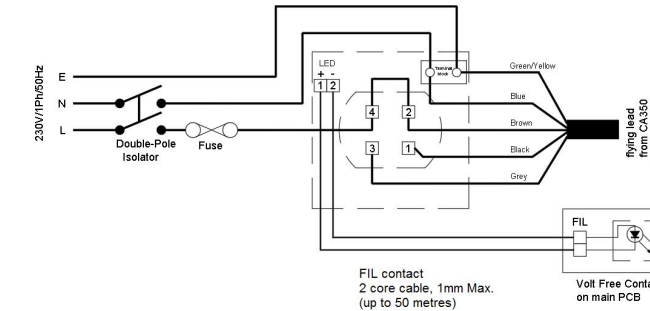

Two speed control via light switch

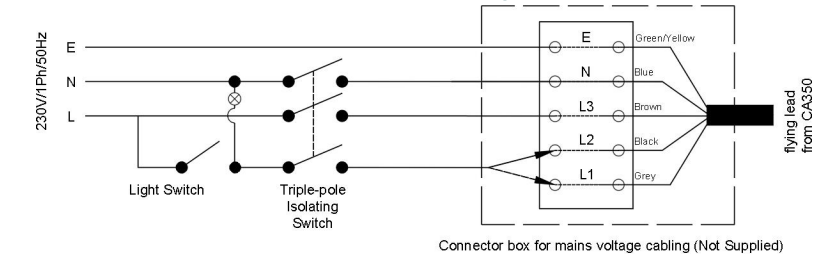

Two speed control via light switch and medium speed activation via remote sensor

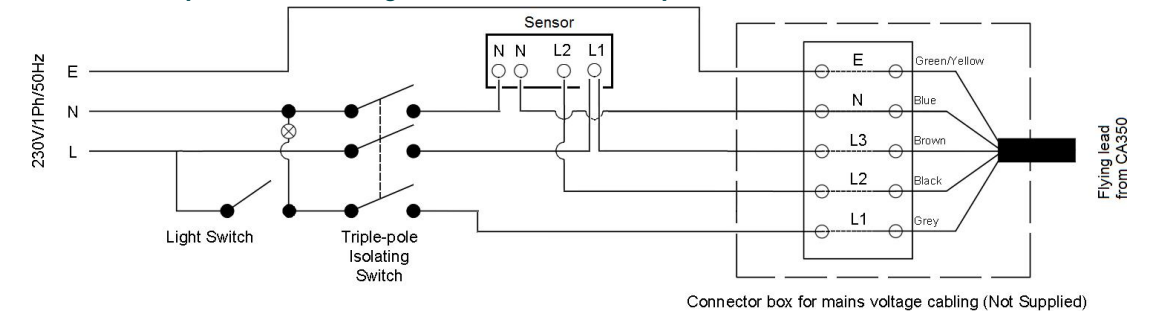

Two speed control via volt free contact switch

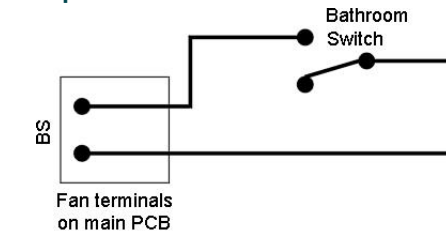

1 core cable, 1mm Max.
(up to 50 metres)

Controls

ComfoControl Basic

Product code: 659 000 120



The Zehnder CCL is a three position switch designed to enable the user to manually select the desired ventilation systems flow rate

Key Benefits

- 3 separate ventilation flow rate options to select in 1 controller

Technical Specification

Mounting options	Recessed / Surface
Supply voltage	Mains power - 230 V / single-phase / 50Hz
IP rating	IP20
RAL colour	9010

Dimensions (recessed)

Height	80 mm
Width	80 mm
Depth	9 mm

Dimensions (surface mounted)

Height	80 mm
Width	80 mm
Depth	40 mm

ComfoControl Basic LED

Product code: 659 000 300



The Zehnder CCBL is a three position switch designed to enable the user to manually select the desired ventilation systems flow rate and provide system notifications

Key Benefits

- 3 separate ventilation flow rate options to select in 1 controller
- Service and Maintenance alert

Technical Specification

Mounting options	Recessed / Surface
Supply voltage	Mains power - 230 V / single-phase / 50Hz
IP rating	IP20
Recommended cable	FIL contact only - 2 core cable, 1 mm Max. (up to 50 metres)
RAL colour	9010
Recommended mounting box	659 000 310

Dimensions (recessed)

Height	83 mm
Width	83 mm
Depth	7 mm

Dimensions (surface mounted)

Height	83 mm
Width	83 mm
Depth	44 mm

RF-PCB - ComfoAir

Product code: 655 000 770



The Zehnder RF-PCB enables the CCRFZ (655 000 755) controller to be used with the ventilation system without the need for the ComfoSense 67.

Key Benefits

- Acts as a wireless receiver to the CCRFZ (655 000 755) controller without the need for the ComfoSense 67
- Built into the unit and not visible from the outside

Technical Specification

Mounting options	Inside the unit direct to the PCB
------------------	-----------------------------------

AQR

Product code: AQR



The Zehnder AQR remote air quality sensor enables a signal to be sent to the ventilation system to automatically place the unit into a higher flow rate.

Key Benefits

- Set activation level covering a range of pollutants such as hydrogen, CO, methane, ethanol and isobutane
- Adjustable overrun timer between 2-40 minutes
- Can be fitted with locking security straps to prevent tampering
- Suitable for locating where temperatures don't exceed 45°C

Technical Specification

Mounting options	Surface
Supply voltage	Mains power - 230 V / single-phase / 50Hz

Dimensions (surface mounted)

Height	86 mm
Width	93 mm
Depth	37 mm

HHR

Product code: HHR



The Zehnder HHR remote humidity sensor enables a signal to be sent to the ventilation system to automatically place the unit into a higher flow rate.

Key Benefits

- Set humidity activation between 30-90% relative humidity
- Adjustable overrun timer between 2-40 minutes
- Can be fitted with locking security straps to prevent tampering
- Suitable for locating where temperatures don't exceed 45°C

Technical Specification

Mounting options	Surface
Supply voltage	Mains power - 230 V / single-phase / 50Hz

Dimensions (surface mounted)

Height	86 mm
Width	93 mm
Depth	37 mm

PIRR

Product code: PIRR



The Zehnder PIRR remote passive infra-red movement sensor enables a signal to be sent to the ventilation system to automatically place the unit into a higher flow rate.

Key Benefits

- Senses movement up to 7 m away
- Adjustable overrun timer between 2-40 minutes
- Can be fitted with locking security straps to prevent tampering
- Suitable for locating where temperatures don't exceed 45°C

Technical Specification

Mounting options	Surface
Supply voltage	Mains power - 230 V / single-phase / 50Hz

Dimensions (surface mounted)

Height	86 mm
Width	93 mm
Depth	37 mm

THR

Product code: THR



The Zehnder THR remote temperature sensor enables a signal to be sent to the ventilation system to automatically place the unit into a higher flow rate.

Key Benefits

- Set temperature activation between 5-35°C
- Fixed 2 minute overrun timer
- Can be fitted with locking security straps to prevent tampering
- Suitable for locating where temperatures don't exceed 45°C

Technical Specification

Mounting options	Surface
Supply voltage	Mains power - 230 V / single-phase / 50Hz

Dimensions (surface mounted)

Height	86 mm
Width	93 mm
Depth	37 mm

For use with

Our range of ComfoAir MVHR units can be used in conjunction with ComfoWell. The modular ComfoWell manifold can be combined with multiple circular connections for rigid round or semi-rigid connections. Along with filter boxes and attenuated manifold options, the ComfoWell is the perfect bespoke air distribution system for our ComfoAir MVHR units.

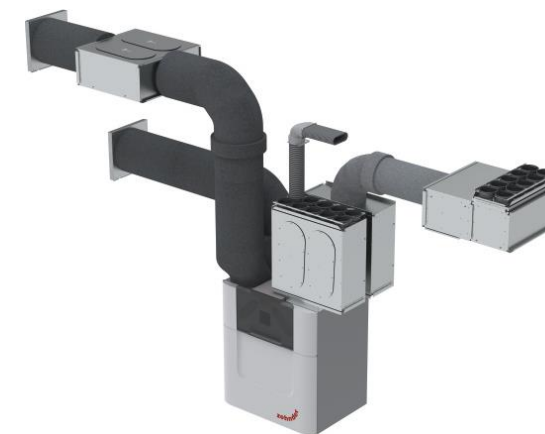

TO VIEW OUR COMFOWELL INFORMATION

[CLICK HERE](#)

BIM/CAD Components

If you would like to download the BIM / CAD files for this or any other of our products then please visit our BIM library.

TO VISIT OUR BIM/CAD LIBRARY

[CLICK HERE](#)

Installation Instructions

If you would like to download the installation files for this or any other of our products then please visit our download page by clicking the link below.

[TO VISIT OUR DOWNLOAD PAGE](#)

[CLICK HERE](#)

Our Informational Videos



Watch our video on how to change the Zehnder ComfoAir 350 filters.

[TO WATCH OUR VIDEO](#)

[CLICK HERE](#)



Watch our video on how to clean the install ComfoTube Flat 51 ductwork.

[TO WATCH OUR VIDEO](#)

[CLICK HERE](#)

Consultant Specification

Specification

The unit shall consist of a body manufactured in powder coated sheet steel. The unit shall be fully insulated using high quality EPP to maintain excellent thermal characteristics and prevent shrinkage over time. It shall have EC motors with sealed for life bearings. The fans impellers should be low pressure centrifugal type with forward curved blades within ABS scroll housing. The heat exchanger shall be a multi-plate, counter flow design constructed from Polystyrene with laser welded joints and shall retain up to 88% of the temperature differential of outgoing air with the option to upgrade to an enthalpy heat exchanger for latent and sensible heat transfer plus moisture recovery negating the need for a condensate drain.

The unit shall contain filters manufactured from synthetic material which has been tested to a minimum of [ISO Coarse \(G4\)](#) standard with the option to upgrade to [ISO ePM1 \(F7\)](#). The filters shall be pleated to reduce the pressure drop and required cleaning time. The unit shall have rotatable 150 mm duct connections, and be suitable for vertical wall mounting or floor stand.

The unit shall have 100% full summer by-pass and provide filtered supply air 365 days of the year, even under bypass conditions. The unit shall contain a temperature sensor for each air stream to ensure correct and logical operation of the bypass damper by evaluating differential as well as absolute temperature to maximise the opportunity for free cooling.

The unit shall be constructed to have a removable cover to allow full maintenance access. The removable cover shall enable access to the supply/extract fan, heat exchanger and access to electrical connections. The motors shall be suitable for removal without the requirement for the unit to be removed from situ and be available as spare parts for a minimum of 10 years even after ceasing manufacture of the unit.

The unit shall conform to LVD and EMC standards and be CE Marked in addition to having an EU compliant energy rating label (SEC) with a minimum grade of A. The unit shall conform to [UK Electrical Equipment \(Safety\) Regulations](#) and [Electromagnetic Compatibility Regulations](#) and be UKCA Marked. The unit shall be manufactured by Zehnder.

Operation

The supply and extract unit shall be a ComfoAir manufactured by Zehnder and shall be suitable for vertical wall or in a cupboard in accordance with the specification.

The fresh filtered air from outside shall be supplied to each of the habitable rooms and pre-heated by the warm extract air from the wet areas, such as kitchen or bathroom, via the plastic counter flow heat exchanger. The unit shall vary its speed of the EC motors automatically when it receives a signal from one of the inbuilt sensors or via external switches.

The unit shall have the ability to adjust and commission the supply and extract motors independently via the front mounted in-built interface. The motors shall both offer 100% variable speed control.

Controls

All ComfoAir units shall contain the following functions within the unit pre-wired and factory fitted by the manufacturer:

- 100% variable supply and extract motor control
- 3 Variable speed flow rate set points
- Automatic filtered summer bypass
- Heat exchanger frost protection
- Integral service, fault and operation indicators
- Control panel PIN protection
- Tool free filter access
- Variable overrun and delay on timer
- Switched live input
- Volt free contact