

Zehnder Silvertop



Installation, Service and User Manual

always the best climate



Contents

1.	Technical specifications	5
1.1.	Electrical performance data	5
1.2.	Dimensional data	5
1.3.	Zehnder Silvertop 06...23	6
1.4.	Zehnder Silvertop 35	6
1.5.	Zehnder Silvertop 52	7
2.	General	7
3.	Upon receipt of the material	9
3.1.	Quality checks	9
3.2.	Unpacking	9
3.3.	Storage	9
4.	End of service life	9
5.	Packaging and packages	10
6.	Identification and labelling	10
7.	Overview and construction	12
7.1.	General overview of the unit	12
7.2.	Electrical board	13
7.3.	Control terminals and user connections	14
8.	Installation	16
8.1.	Handling	16
8.2.	Setting up	16
8.3.		Installation of the plate heat exchanger syphon
8.4.	Installation of the plate heat exchanger syphon	18
8.5.	Installation of the remote coil syphon	19
8.6.	Connection to the air network	20
8.7.	Connection of the power supply	20
9.	Electrical connection of external devices	21
9.1.	External control of low-speed forced operation (reduced operation)	21
9.2.	External control of high-speed forced operation (normal operation)	21
9.3.	External shutdown control	21
9.4.	External fire protection control	21
9.5.	Motorised intake air register control (MSR)	21
9.6.	Motorised exhaust air register control (MER)	22
9.7.	Night cooling signal (LOBBY)	22
9.8.	Alarm signal	22
9.9.	Remote fire stop - RFS	22
9.10.	Autonomous trigger detector - ATD	23
10.	Connection of remote coils in ducts	23
10.1.	Remote hot water coil	23
10.2.	Remote cold water coil	25
10.3.	Remote changeover coil (CO coil)	26
10.4.	Remote direct expansion (DX) cooling/heating/reversible coil	27
11.	General function	28
11.1.	Installation of the thermal sequence	28
11.2.	Start-up sequence	28
11.3.	Shutdown sequence (post-ventilation)	28

Contents

12.	Starting up	29
13.	Maintenance	29
13.1.	Annual general quality check	29
13.2.	Filter quality check	29
13.3.	Removal and installation of the exchanger condensate tray	30
13.4.	Removal and installation of the plate heat exchanger	30
14.	Troubleshooting - maintenance	31
14.1.	Connection and setting of the filter control pressure switch	31
14.2.	Connection and setting of the fan feedback pressure switches (ECO and DIVA)	31
14.3.	Connection and setting of pressure transducers (LOBBY)	32
14.4.	Connection and setting of pressure transducers (MAC2 and QUATTRO)	33
14.5.	Overheating safety thermostats THS and THSD	34
14.6.	Replacing the internal memory battery	35
15.	Electrical control wiring diagram	36
16.	Electrical power diagram	38
16.1.	Single-phase 230V AC electric heating and defrosting coils	38
16.2.	Three-phase 400V AC electric heating and defrosting coils	40
16.3.	Motorised fans	41
17.	Zehnder Easy 5.0 controller	46
18.	SEASON controller	46
18.1.	General	46
18.2.	Overview and construction	46
18.3.	Electrical compartments and user controls	47
18.4.	General operating principle	48
18.5.	User settings	48
18.5.1.	Thermostat TH1 (heat recovery)	48
18.5.2.	Thermostat TH2 (cold recovery)	48
18.5.3.	Thermostat TH3 for frost protection	48
18.6.	Connecting and setting external user devices	49
18.7.	Troubleshooting and maintenance	49
18.8.	General SEASON wiring diagram	50
18.9.	Electrical wiring diagram for SEASON motorised fans	51
19.	Air performance curves	56
20.	Commissioning report	58
	EU Declaration of conformity	62

Legal regulations

All rights reserved.

This manual has been compiled with the utmost care. Nevertheless, the publisher accepts no liability for damage caused by missing or incorrect details in this operating manual. We reserve the right at any time and without prior notification to change the content of these instructions in part or as a whole.

The information contained in these documents is the property of Zehnder Group. Any form of publication, whether in whole or in part, requires the written approval of Zehnder Group. In-house duplication, designated for the evaluation of the product or for proper use, is permitted and not subject to approval.

Zehnder manufacturer's warranty

The current device terms are available online

(<https://www.caladair.com/en/espace-client/media/sales-terms-and-conditions>).

Hardcopies can be obtained via our established sales channels..

Trademarks

All trademarks are recognised, even if they are not separately labelled. A missing label does not mean that an article or sign is free of trademark rights.

© 2021 Zehnder Group

Safety notes

In accordance with the regulations in force, the installation and maintenance of the equipment must only be carried out by technically qualified personnel authorised for this type of equipment and work.

Use the necessary Personal Protective Equipment to avoid injury from electrical, mechanical (injuries from contact with metal sheets, sharp edges, etc.) and acoustic hazards.

Do not use the appliance for any purpose other than that for which it is designed. This device may only be used to convey air free of hazardous compounds, construction dust, etc.

Move the device as described in the chapter on handling.

Grounding must be done in accordance with the applicable standards. Never switch on an ungrounded appliance.

Before carrying out any work, make sure that the equipment is switched off and wait for the moving parts of the ventilation unit to come to a complete stop before opening the doors, panels and access hatches.

During operation, inspection and service panels, doors and hatches must always be fitted and closed.

The appliance can only be switched on and off via the isolator switch.

The safety and control equipment must not be removed, short-circuited or disabled.

The installation must comply with fire safety regulations.

All waste produced must be handled in accordance with the regulations in force.

It is the responsibility of the installer of the equipment to ensure compliance with the regulations concerning noise emissions inside the building and to adapt the installation and location conditions if necessary.

We accept no liability for damage resulting from misuse of the equipment, unauthorised repair or modification or failure to observe these instructions.

Applicable from serial number : CD225200

1. Technical specifications

1.1. Electrical performance data

Model Zehnder Zehnder Silvertop	Power Electric motor (W)	Operating temp. (°C / °C)	Protection type	Thermal insulation class	FIRST, PREMIUM BC and SEASON		INFINITE BC and SMART		PREMIUM BE		INFINITE BE	
					Nominal voltage (V/Ph/Hz)	Electrical consumption (A)	Nominal voltage (V/Ph/Hz)	Electrical consumption (A)	Nominal voltage (V/Ph/Hz)	Electrical consumption (A)	Nominal voltage (V/Ph/Hz)	Electrical consumption (A)
06	2 x 169	-20 / 60	IP54/B	ITP	230/1/50	3.4	230/1/50	8.8	230/1/50	8.8	230/1/50	14.2
08	2 x 170	-20 / 60	IP54/B	ITP	230/1/50	4.0	230/1/50	14.8	230/1/50	14.8	230/1/50	25.7
15	2 x 480	-20 / 40	IP54/B	ITP	230/1/50	4.9	400/3+N/50	9.7	230/1/50	21.2	400/3+N/50	15.1
23	2 x 750	-20 / 40	IP54/B	ITP	230/1/50	7.2	400/3+N/50	13.0	400/3+N/50	13.0	400/3+N/50	22.8
35	2 x 1000	-20 / 50	IP54/B	ITP	400/3+N/50	3.8	400/3+N/50	21.2	400/3+N/50	19.0	400/3+N/50	36.3
52	2 x 1700	-20 / 40	IP54/B	ITP	400/3+N/50	5.8	400/3+N/50	27.4	400/3+N/50	23.1	400/3+N/50	44.7

* ITP: integrated thermal protection

1.2. Dimensional data

Model	Ø	A	B	C	D	D1	D2	E	E1	E2	F	F1	G	J	J1	K	L	M1	M2	M3	T1	SEASON SMART	PREMIUM SMART INFINITE	PREMIUM INFINITE
	mm	mm	mm	mm	mm	mm	mm	mm	mm	mm	mm	mm	mm	mm	mm	mm	mm	mm	mm	mm	inch	kg	kg	kg
06	200	1105	570	1040	145	-	-	225	365	225	135	150	385	75	130	265	545	720	-	-	1/ 2	175	180	185
08	250	1265	700	1150	170	-	-	235	415	270	160	225	485	75	180	275	625	880	-	-	1/ 2	250	255	260
15	315	1590	750	1200	230	-	-	315	500	315	210	190	585	100	230	435	770	1200	-	-	1/ 2	320	330	335
23	400	1735	1065	1340	270	-	-	330	535	330	250	420	765	100	230	440	855	1350	-	-	1/ 2	490	500	510
35	450	1950	1210	1495	295	-	-	340	615	405	280	515	805	100	305	475	960	-	685	685	1/ 2	635	650	660
52	-	2185	1520	1625	70	405	960	140	140	140	50	260	1115	100	380	525	1120	-	760	760	1	875	890	905

G - J - J1 - T1 for water coil (PREMIUM BC / INFINITE BC)
(T1= diameter steel pipe with gas thread)

1.3. Zehnder Silvertop 06...23

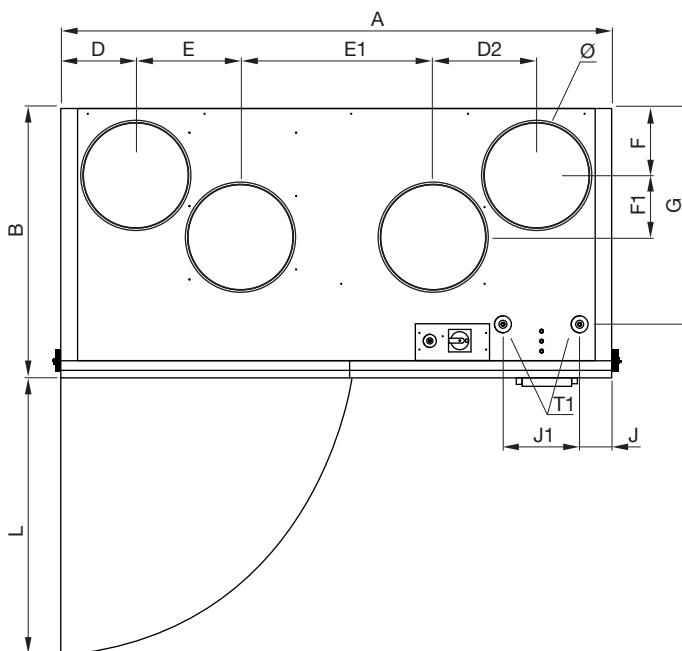
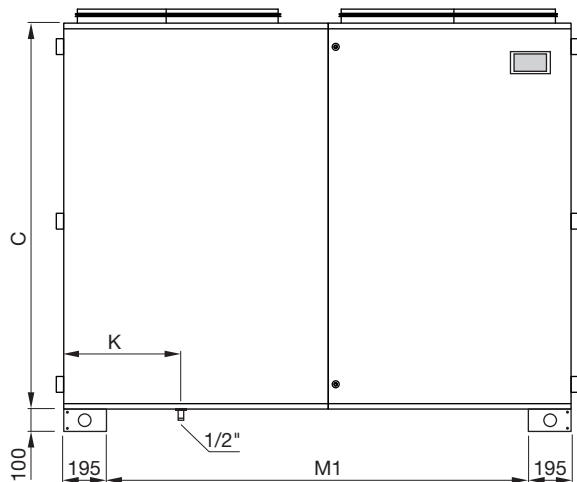

1.4. Zehnder Silvertop 35

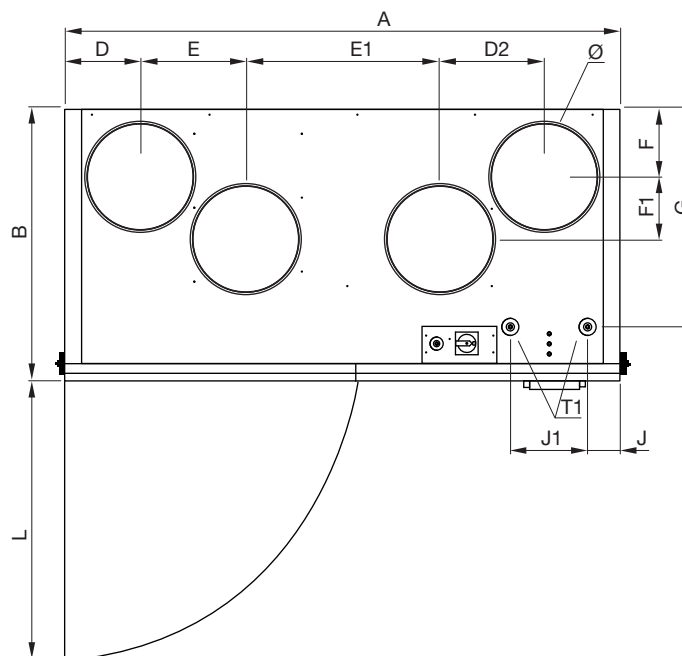
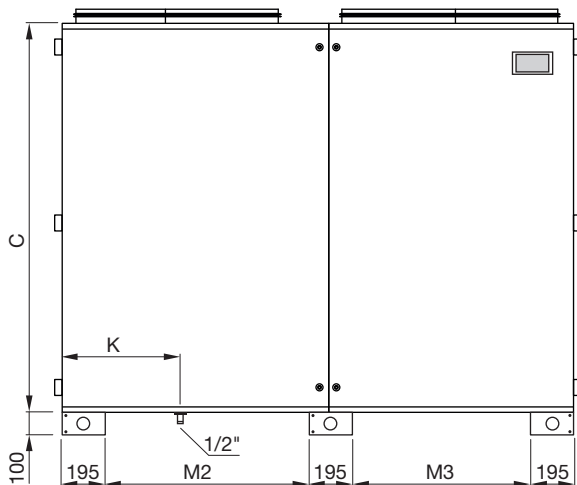

1.5. Zehnder Silvertop 52

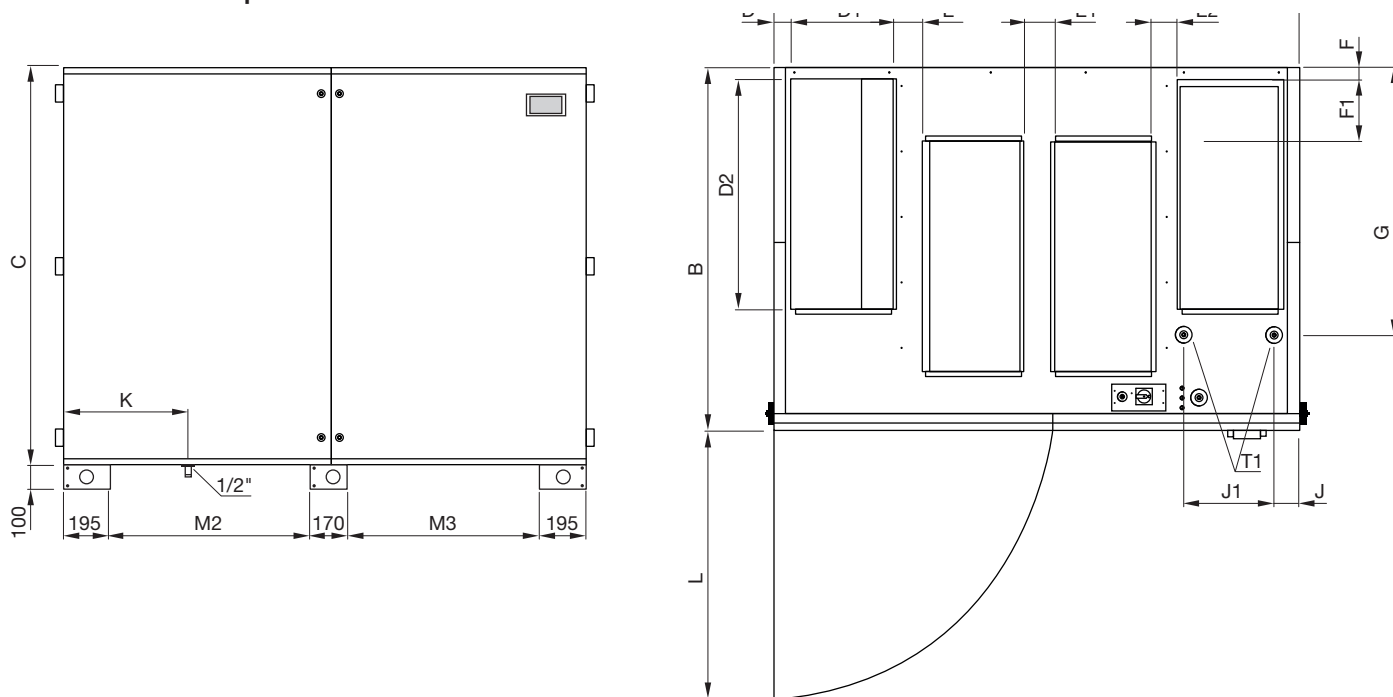

2. General

Zehnder Silvertop is a range of high-efficiency, plug & play, compact, single-piece indoor ventilation units. The range is available in 6 sizes to cover unit flows up to 5500m³/h.

It is equipped as standard with the Zehnder Easy 5.0 controller, which provides intelligent ventilation and thermal management (except for the SEASON version, see chapter 18 SEASON CONTROLLER). The Zehnder Easy 5.0 controller is a communicative device (Modbus RTU/TCP or Bacnet MSTP/IP) and has an integrated web server that is compatible with any HTML5 browser. The Zehnder Easy 5.0 controller is described in a separate manual.

	Integrated thermal control and equipment		
	Electric defrosting coil EDC	Hot water coil BC	Electric coil BE
FIRST			
SMART	✓		
PREMIUM BC		✓	
PREMIUM BE			✓
INFINITE BC	✓	✓	
INFINITE BE	✓		✓

	Fan control type	Description
SEASON	Constant speed (without controller)	Fan speed can be adjusted manually by means of an individual potentiometer located on the front of the fan unit.
ECO	<p>Constant speed</p>	<p>2 adjustable independent fan speeds</p> <p>2 adjustable independent time periods for each speed</p>
LOBBY	<p>Constant pressure</p>	<p>2 adjustable independent fan pressures</p> <p>2 adjustable independent time periods for each speed</p>
MAC2	<p>Constant air volume</p>	<p>2 adjustable independent fan air volumes</p> <p>2 adjustable independent time periods for each air volume</p>
DIVA	<p>CO₂ control via fan speed</p>	<p>The fan speed varies continuously and proportionally between 2 fan speeds depending on the CO₂ concentration measured at the extract</p>
QUATTRO	<p>CO₂ control via fan air volume</p>	<p>The fan air volume varies continuously and proportionally between 2 fan speeds depending on the CO₂ concentration measured at the extract</p>

The Zehnder Silvertop range is supplied as standard with a modulating bypass that provides the following functions:

- Protection against icing of the plate heat exchanger
- Management of the thermal recovery rate
- Free cooling
- Night cooling
- Free heating

If you wish to extend the functional capabilities, the Zehnder Silvertop range of ventilation units can be coupled with the optional Combi Box modules, which allow the following coils to be installed in the duct:

- Cold water coil
- Direct expansion coil (hot and/or cold)
- Changeover coil
- Hot water coil (to replace the coil integrated in the unit).

Note: The Zehnder Easy 5.0 controller can only accommodate:

- A heating coil + a cooling coil
- A changeover coil alone.

The Zehnder Easy 5.0 controller cannot accommodate:

- A heating and cooling coil for dehumidification
- A heating coil and a changeover coil.

3. Upon receipt of the material

3.1. Quality checks

On receipt of the material, check the condition of the packaging and the material, as well as the number of packages. In case of damage, make detailed comments on the carrier's delivery note and inform your supplier immediately.

3.2. Unpacking

When unpacking the equipment, check the following points:

- Presence of total number of packages
- Presence of the expected accessories (electrical equipment, sleeves, (external) controls, etc.)

Remove the protective film from the sheets.

After unpacking the material, the waste must be disposed of according to local regulations and standards.

No packaging should be released into the environment.

3.3. Storage

As long as the unit is not installed and connected to the air distribution network, it must be stored in a sheltered, dry place at a temperature between -20 °C and +40 °C as the packaging is not suitable for storage in bad weather.

4. End of service life

Through its membership of the eco-organisation ECOLOGIC, CALADAIR meets the financing obligations for the collection, removal and treatment of waste electrical and electronic equipment.

When installing or uninstalling this equipment, the user or installer can contact the Ecologic company, which will offer a collection solution to dispose of the obsolete product in a suitable way.

Telephone: +33 (0)1 30 57 79 09

Internet: www.e-dechet.com

5. Packaging and packages

The Zehnder Silvertop ventilation unit is delivered mounted on wooden palletes or PCB feet and wrapped in a protective plastic film. The fragile parts are protected by cardboard pieces.

6. Identification and labelling

The ventilation unit can be identified by its identification label:

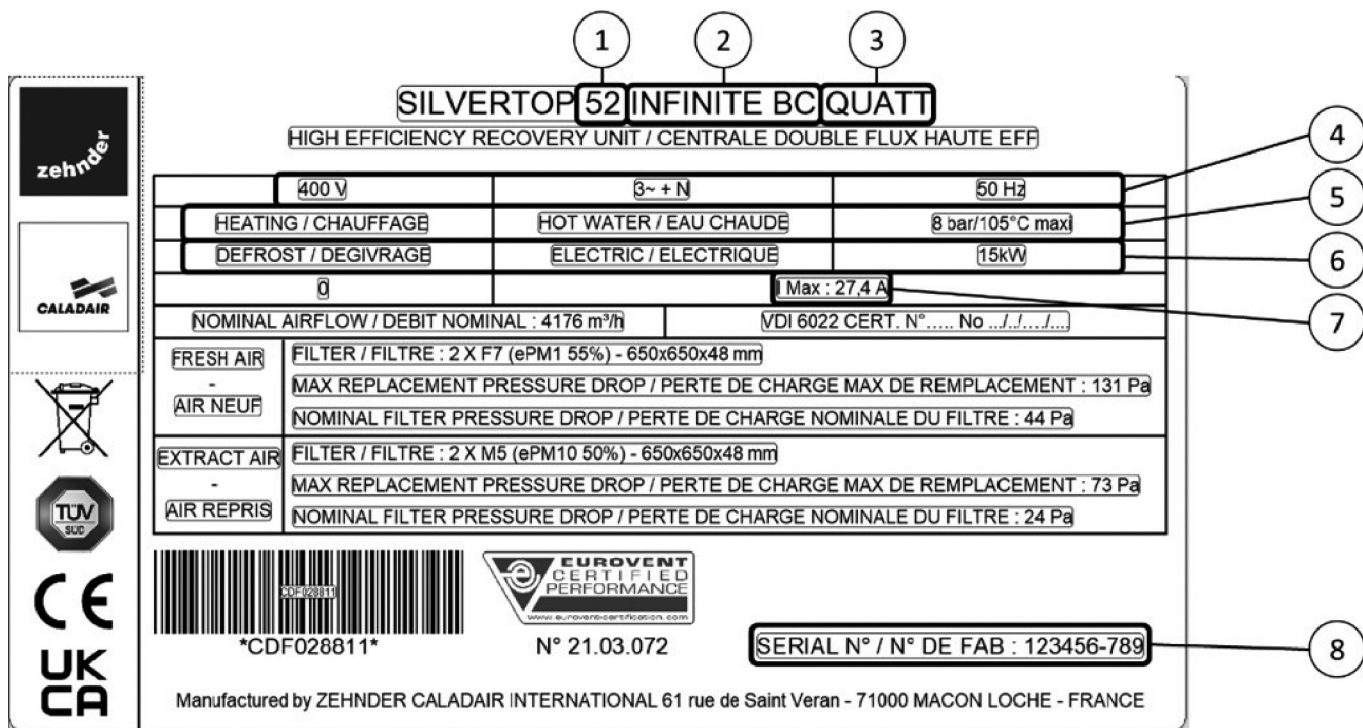

1	Unit size
	06
	08
	15
	23
	35
	52

See air performance curves
Chapter 19 AIR PERFORMANCE CURVES

2	Type of control and integrated thermal equipment	
	SEASON	Fan control via potentiometer and heat recovery control via thermostats (no Zehnder Easy 5.0 controller)
	FIRST	Zehnder Easy 5.0 controller without integrated coil
	SMART	Zehnder Easy 5.0 controller with integrated electric defrost coil control (EDC)
	PREMIUM BE	Zehnder Easy 5.0 controller with integrated electric heating coil control (EHC)
	PREMIUM BC	Zehnder Easy 5.0 controller with integrated hot water heating coil control (BC)
	INFINITE BE	Zehnder Easy 5.0 controller with control of integrated electric defrosting coil and integrated electric heating coil (EDC + EHC)
	INFINITE BC	Zehnder Easy 5.0 controller with control of integrated electric defrost coil and integrated electric hot water heating coil (EDC + BC)

3	Fan control type	
	ECO	Constant speed
	LOBBY	Constant pressure
	MAC2	Constant volume
	DIVA	CO ₂ in variable speed
	QUATTRO	CO ₂ in variable discharge capacity

4	Type of power supply	
	400V - 3~ + N - 50 Hz	Three-phase + Neutral
	230V - 1~ - 50 Hz	Single-phase

5	BE: Effective capacity of the electric heating coil in (kW) BC: Temperature/Max. pressure	
---	--	--

6	Effective capacity of the electric intake air preheating coil (defrost) in (kW)	
---	---	--

7	Maximum absorbed current in (A)	
---	---------------------------------	--

8	Production number to be mentioned in all communication with the supplier	
---	--	--

7. Overview and construction

7.1. General overview of the unit

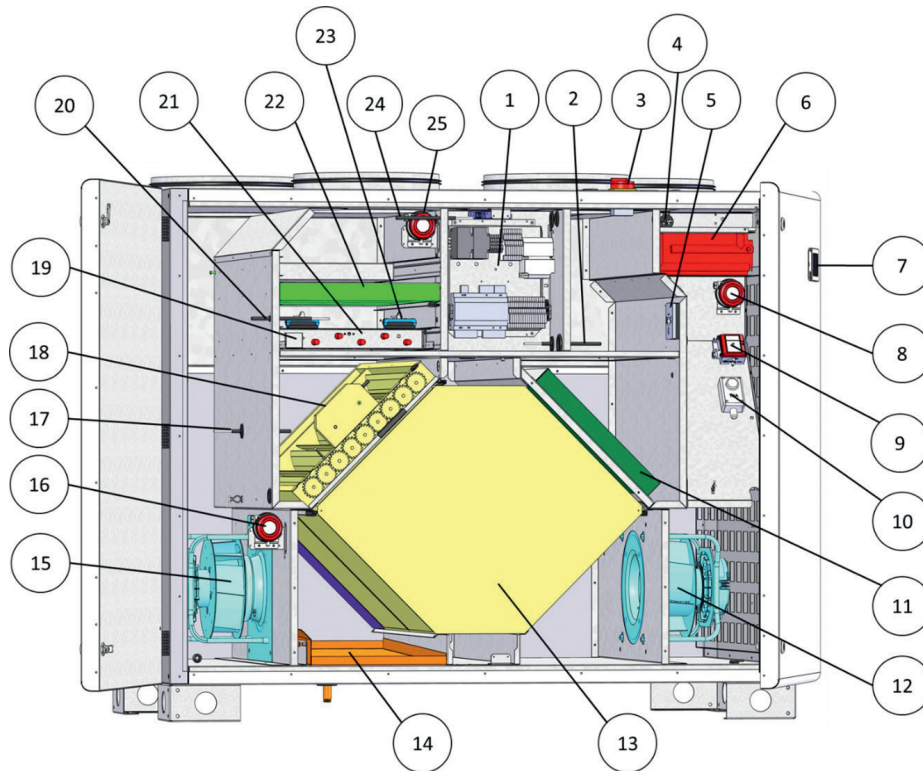

The image may differ from the actual model but the principle of how to position the components remains valid.

Reference point	Designation	Component
1		Electrical board
2	SRG	Extract temperature sensor
3		Main power cut-off switch
4	SSG	Supply temperature sensor
5	CO ₂	CO ₂ sensor (DIVA or QUATTRO)
6	BE/BC	Electric heating coil (PREMIUM BE / INFINITE BE) or hot water heating coil (PREMIUM BC / INFINITE BC)
7	PG 5.0	Local touchscreen control
8	DEP S	Pressure control switch for supply air fan (ECO / DIVA)
	TRP S	Supply pressure transducer (LOBBY)
	TRP S	Pressure transducer for supply air volume measurement (MAC2 / QUATTRO)
9	TRP R	Extract air pressure transducer (LOBBY)
10	THA	Frost protection thermostat (PREMIUM BC / INFINITE BC)
	THS	Overheating safety thermostat for electric heating coil (PREMIUM BE / INFINITE BE)
11	RF	Extract filter
12	SAF	Supply air fan
13	REC	Plate heat exchanger
14		Plate heat exchanger condensate tray

Reference point	Designation	Component
15	EAF	Extract air fan
16	DEP R	Pressure switch for extract fan operation (ECO / DIVA)
	TRP R	Pressure transducer for extract air volume measurement (MAC2 / QUATTRO)
17	SBD	Defrost coil temperature sensor (SMART / INFINITE)
18	BIM	Bypass register
19		Bypass register actuator
20	THSD	Overheating safety thermostat for electric defrosting coil (intake air preheating for protection against frost) (SMART / INFINITE)
21	SDG	Defrost temperature sensor (exhaust air for bypass management)
22	EDC	Electric defrosting coil (intake air preheating) (SMART / INFINITE)
23	SF	Supply filter
24	KS1	Static relay for defrost coil (EDC)
25	SEG	Outdoor temperature sensor (intake air)
26	DEP SF	Pressure switch to control the clogging of the supply filter (intake air)

7.2. Electrical board

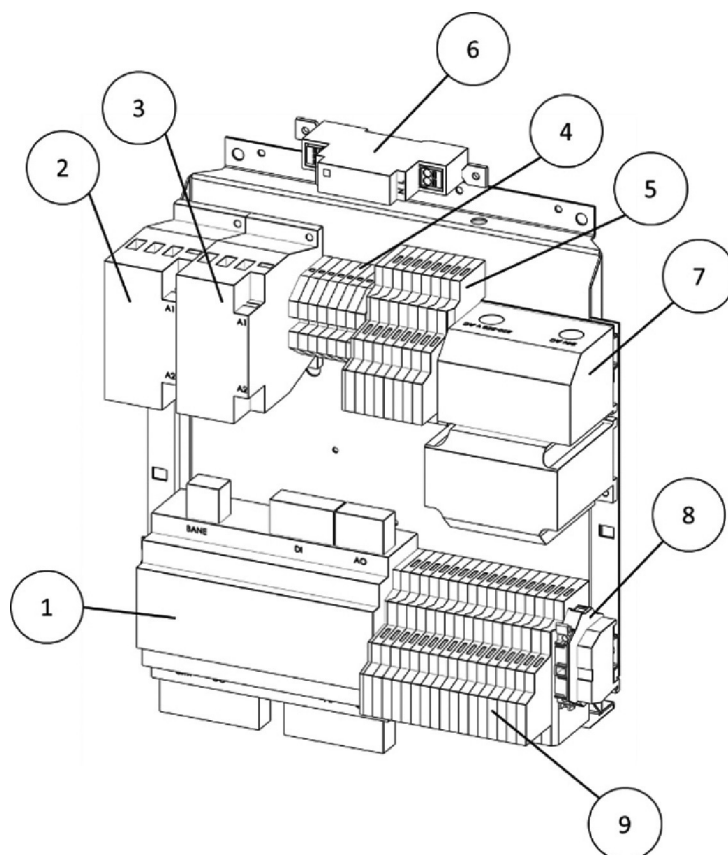

Reference point	Designation	Component
1	CLD-283	Controller
2	K1	Electric heating coil (EHC) contact transmitter
3	KD	Electric defrosting coil contact transmitter (intake air preheating) (EDC)
4		Supply and extract air fan terminals (SAF and EAF)
5		Upper control and user terminals (optional), see chapter 7.3 Control terminals and user connections
6		Power supply transformer 230V AC / 24V DC for local touch control PG 5.0
7	TRAFO	Control transformer 230V AC / 24V AC
8		Fuse holder terminal 3.15A T
9		Lower control and user terminals (optional), see chapter 7.3 Control terminals and user connections

7.3. Control terminals and user connections

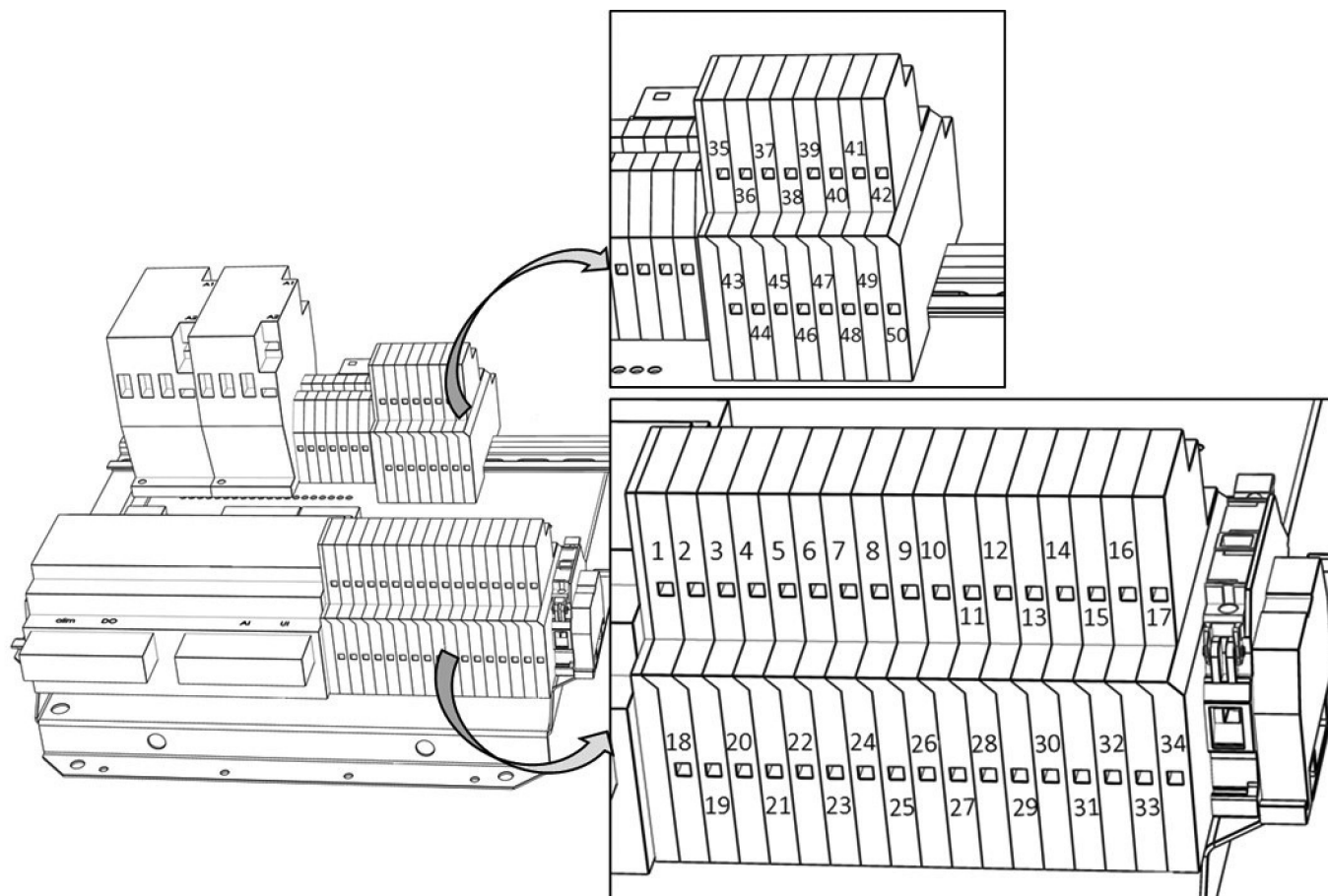

Designation	Definition	Terminals	Connection
RFS	Remote fire stop	1-2	To be connected to the terminals of an NC contact of the remote fire stop. (Shunt between terminals (1)-(2) at the factory)
ATD	Autonomous trigger detector	3-4	To be connected to the ATD fault contact. (Shunt between terminals (3)-(4) at the factory)
THA	Frost protection thermostat	5-6	To be connected to terminals (C) and (2) of the THA frost protection thermostat (units in the PREMIUM BC and INFINITE BC versions equipped with a hot coil BC) Shunt between terminals (5)-(6) at the factory (FIRST/SMART)
THS	Safety thermostat	5-6	To be connected to terminals (C) and (2) of the THS safety thermostat (units in the PREMIUM BE and INFINITE BE versions equipped with an electric heating coil) Shunt between terminals (5)-(6) at the factory (FIRST/SMART)
Zehnder EDT2	Power supply +24V DC Zehnder EDT2 room touch control	7-8	To be connected to the (N) and (+24V) terminals of the Zehnder EDT2 room touch control respectively (observe polarity).
LS RO	Low-speed remote order	9-10	To be connected to an external NO (normally open) contact
HS RO	Low-speed remote order	11-12	To be connected to an external NO (normally open) contact
ARR EXT	External stop	13-14	To be connected to an external NO (normally open) contact
V3V BC	3-way valve Hot water heating coil	15-16-17	To be connected to the modulating 3-way valve of the hot water coil (see chapter 10.1 Remote hot water coil)
HEATING NEED	Hot water heating coil pump	18 + DO3 of the controller	To be connected to the ON/OFF switch of the hot water circulator (Attention: 24V AC output to be relayed) see chapter 10.1 Remote hot water coil
COOLING NEED	Cold water cooling coil pump	19 + DO4 of the controller	To be connected to the ON/OFF switch of the cold water circulator (Attention 24V AC output to be relayed) (see chapter 10.2 Remote cold water coil)
AL	Alarm reporting	20 + DO5 of the controller	24V output available if the unit is faulty (Attention 24V AC output to be relayed)
NC Night	Night cooling	22 + DO7 of the controller	24V output available if the unit is linked to the LOBBY EC option for opening the terminal registers during night cooling. (Attention 24V AC output to be relayed)
V3V BF	3-way valve Cooling coil	28-29-30	To be connected to the 3-way valve of the cold water coil (see chapter 10.2 Remote cold water coil)
MSR	Motorised supply register	35 + DO1 of the controller	To be connected to terminals (1) and (2) of the motorised supply air register
MER	Motorised exhaust register	36 + DO2 of the controller	To be connected to terminals (1) and (2) of the motorised extract air register
THSD	Overheating safety thermostat for electric intake air preheating coil	44-45	To be connected to terminals (C) and (2) of the overheating THSD safety thermostat (units in the SMART and INFINITE versions equipped with an electric preheating coil) Shunt between terminals (44)-(45) at the factory (FIRST/PREMIUM)

8. Installation

8.1. Handling

The ventilation unit may only be transported in its installation position.

If the product is handled by a forklift truck, ensure that the truck supports the load-bearing structure. Adapt the choice of handling equipment to the weight of the equipment received (refer to the weight given at the beginning of the document).

If the unit is transported by crane, use a lifting beam and strap the product to keep it in the transport position.

Pay particular attention when placing the product on the ground in order to avoid any impact that could damage the structure and integrity of the product.

8.2. Setting up

The Zehnder Silvertop unit has no roof and should only be installed indoors or sheltered from the weather.

The unit must be placed on supports on a sufficiently rigid surface, if necessary using anti-vibration and adjustable pads to adjust the evenness and prevent the structure from deforming.

In general, install the unit in such a way that weather or ambient temperature cannot damage the internal components of the unit during setup and operation.

8.3. Installation of filter clogging control manometers

As an option, the ventilation unit can be equipped with (Caladair reference: OPT004223) an air filter pressure drop control kit comprising:

- 1 graduated liquid column manometer to be filled on site (measuring range 0-1000 Pa)
- 1 container of coloured filling liquid
- 2 pressure taps
- 1m transparent crystal connecting tube
- Small items (screws, brackets).

Allow 1 kit per filter to be fitted.

The installation of all components is the responsibility of the installer.

The panels that support the pressure measurement points and the measuring device are pre-drilled at the factory for easy installation.

If the installation is required to comply with the requirements of VDI6022, all filters must be fitted with a manometer to monitor filter clogging. This option is mandatory to ensure compliance with the VDI6022 standard.

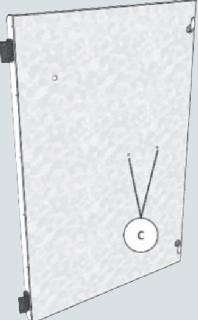
Step	Description	Details
1	<p>Visually locate the 2 holes (C) pre-drilled in the factory on the inner casing of the 2 doors and drill the 2 sheets forming the double casing (double skin) on either side to a diameter of 10mm using a drill bit suitable for drilling sheet metal (e.g. stepped drill bit).</p> <p>Sweep or vacuum the shavings to prevent them from entering the liquid column manometer and the fan unit when refitting.</p>	

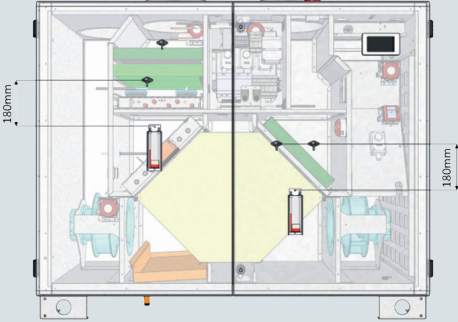
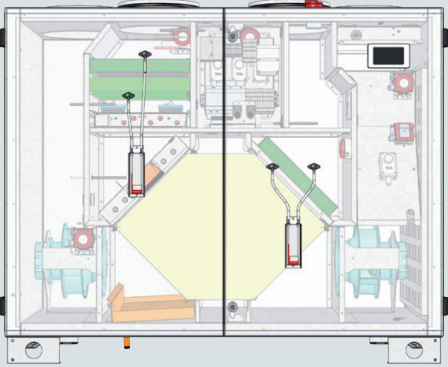
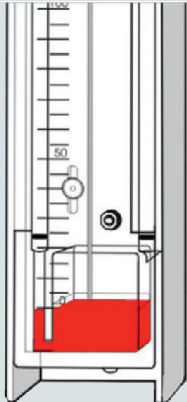
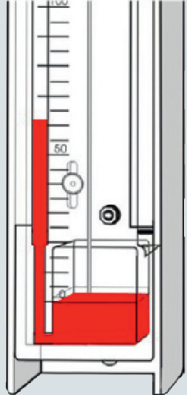
Step	Description	Details
2	Pre-position the pressure measurement device on the outside of the doors, centred and below the level of the 2 pressure taps and secure it with the screws provided. Ensure that the measuring device is vertical and at a sufficient distance (180mm) from the pressure measurement taps to avoid squeezing the crystal tube.	
3	Pre-position the 2 pressure measurement taps on the external face of the panels in the holes previously made.	
4	<p>Connect the pressure measurement taps to the measuring device using the transparent crystal tube, taking into account the (+) and (-) terminals. Adjust the length so that there is no risk of the crystal tube bending, which could affect the measurement.</p> <p>The pressure connection upstream of the filter in the air flow direction is connected to the pressure tap (+) of the liquid manometer.</p> <p>The pressure connection downstream of the filter is connected to the pressure tap (-) of the liquid manometer.</p>	
5	Close the doors and check that the internal tapping of the pressure taps do not come into contact with any internal part of the unit. Trim the tap slightly if necessary.	
6	<p>Fill the manometers using the container provided:</p> <ul style="list-style-type: none"> ▪ Unscrew the left-hand connector (-) ▪ Slowly pour in the liquid to the zero mark ▪ Refit the connector (firm but moderate tightening) ▪ If necessary, adjust the position of the graduated ruler to adjust the zero point. <p>Keep the rest of the container for possible future refilling.</p>	
7	Switch on the ventilation unit and check the tightness of the whole device installed previously.	
8	Check that the manometer is working properly and that the transparent crystal tubes are correctly positioned: the indicated pressure drop must be positive but must not exceed the values indicated in chapter 14.1 Connection and setting of the filter control pressure switch.	

8.4. Installation of the plate heat exchanger syphon



Non-compliance with the installation rules for condensate syphons can lead to the condensate tray overflowing and to internal flooding of the ventilation unit, which can result in damage to the equipment, malfunctions and danger to personnel.

The condensate drain tap provided in the unit has a G 1/2" male connection (see chapter 1.2 Dimensional data).

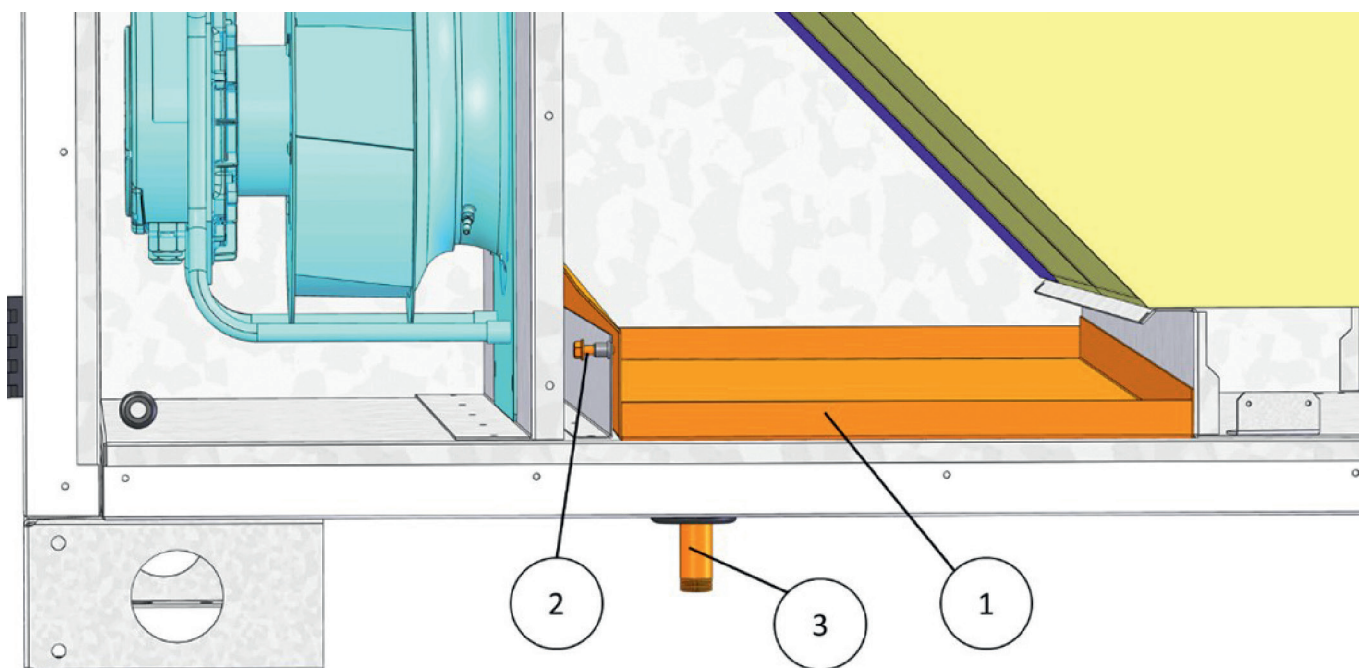

The condensate tray (1) is shown in its final position.

Manually lift the condensate tray (1) to remove the screw (2) in the guide. Then cut the grommet on the underside to allow the connection tube (3) to be positioned below the unit as shown in the photo above, taking care not to damage the grommet which acts as a seal.

Connect a syphon for the exchanger's condensate.

The syphon must always be filled with water in order for it to work. The syphon must be filled when the ventilation unit is started up for the first time, and it may be necessary to manually fill the syphon from inside the central ventilation unit after a long period without condensation.

Provide a separate syphon on each condensate drain hose. The same syphon cannot be used for several drains.

Make sure that the syphon device is perfectly sealed with the connection tap provided in the central ventilation unit in order to prevent any external air from being drawn in.

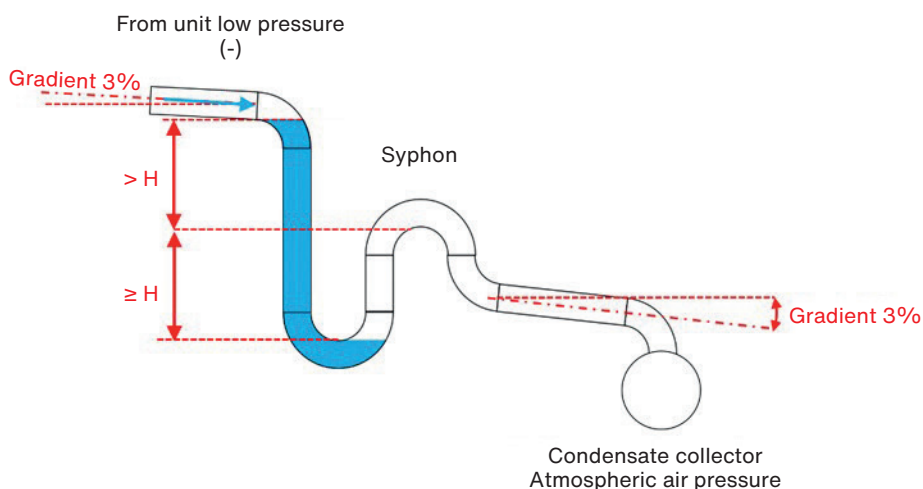

Vacuum (Pa)	H (mm)
100	10
200	20
300	30
400	40
500	50
600	60
700	70
800	80
900	90
1000	100
1100	110
1200	120
1300	130
1400	140
1500	150

The height H depends on the maximum vacuum. If there are no space constraints, a height of H = 120mm can be used for all applications. The installation of a syphon with an integrated non-return device (ball, spout, damper, etc.) means that this minimum height constraint is not necessary.

Ensure that there is a 2-3% gradient towards the condensate drain to drain off the condensate and that the collector is neither under- nor over-pressurised.

8.5. Installation of the remote coil syphon

The requirements of chapter 8.4 Installation of the plate heat exchanger syphon apply.

Unlike the condensate drain of the plate heat exchanger, which is under low pressure relative to atmospheric pressure, the drain of the remote coil is under overpressure relative to atmospheric pressure, which requires a different syphon height.

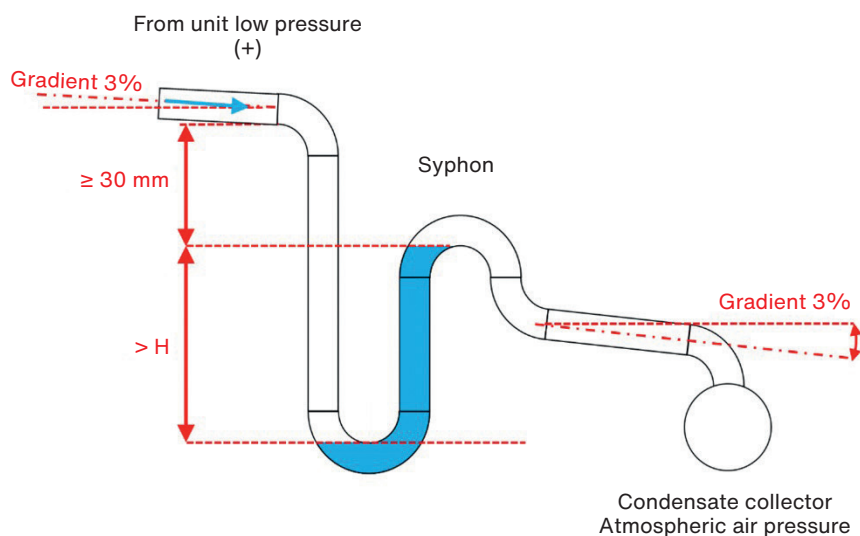

Pressure (Pa)	H (mm)
100	10
200	20
300	30
400	40
500	50
600	60
700	70
800	80
900	90
1000	100
1100	110
1200	120
1300	130
1400	140
1500	150

The height H depends on the maximum downstream pressure of the remote coil. If there are no space constraints, a height of H = 120mm can be used for all applications.

Ensure that there is a 2-3% gradient towards the condensate drain to drain off the condensate. Make sure that the collector is neither under- nor over-pressurised.

8.6. Connection to the air network

For the air connection, select the duct sections according to the dimensions of the flexible sleeves, which must be correctly tensioned. The ducts must be insulated and the first accessories (elbows, tees, etc.) must be located at a distance of at least 2.5 times the diameter in order to avoid any disturbance (turbulence) of the airflow that could affect the proper functioning of the ventilation unit. The weight of the ducts must not lie on the unit.

8.7. Connection of power supply

It is necessary to provide protection devices (circuit breaker, differential) upstream of the ventilation unit's power supply cable.

The power supply cable is connected directly to the back of the isolating switch on the front of the ventilation unit.

Drill a hole in the rubber grommet and feed the power cable through it. Connect the power supply wires directly to the terminal block of the cut-off switch (use crimped cable ends).

Connect the ground wire (PE) to the crimped nut clamp provided for this purpose (use a lug terminal for M6 screws). The ground wire (PE) should be slightly longer than the phase and neutral wires.

Securely attach and clamp the power cable to a fixed part (frame, cable tray, etc.).

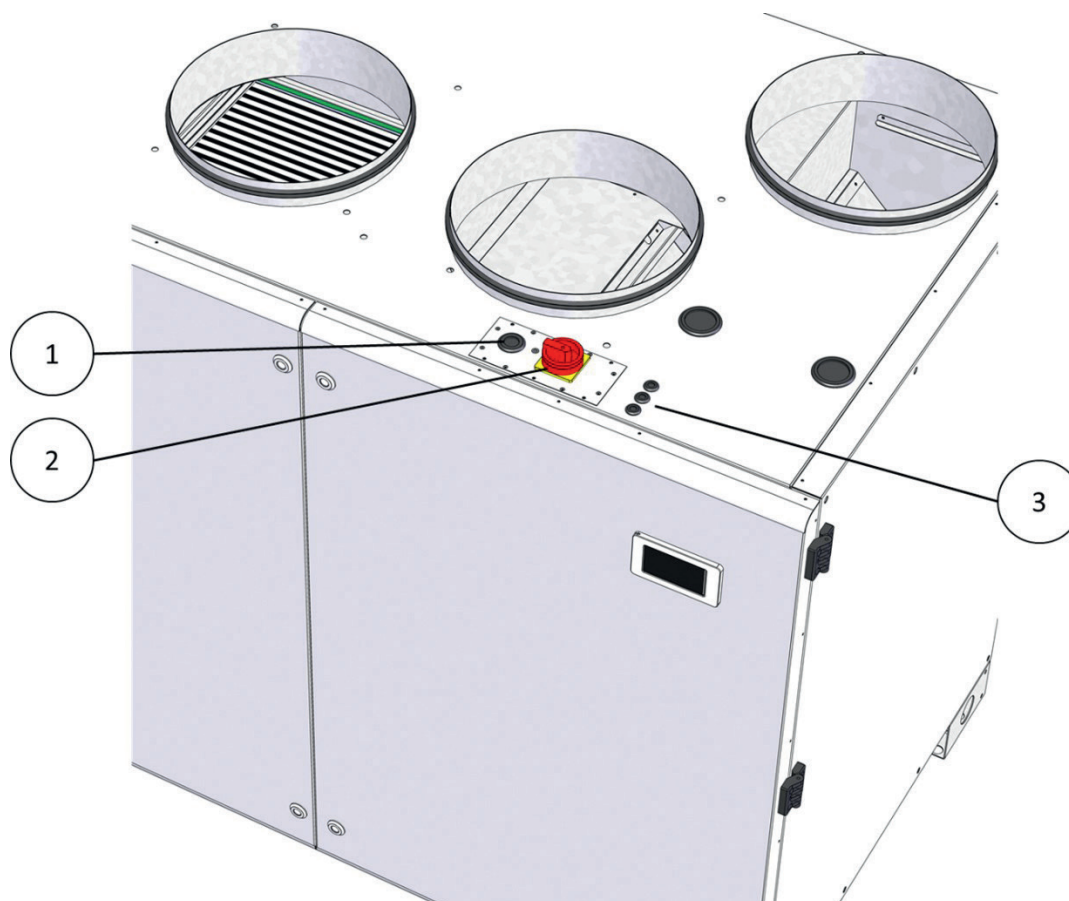

- 1- Power supply grommet
- 2- Cut-off switch
- 3- Additional grommets for connecting optional equipment

9. Electrical connection of external devices

9.1. External control of low-speed forced operation (reduced operation)

The external low speed forced operation command allows the unit to be forced to operate at low speed, regardless of the current operating mode requested by the time schedule. The external control has priority over the time schedule. If the central ventilation unit is switched off by the time schedule, the activation of the external forced low-speed control (reduced operation) will force the central unit to start up at low speed.

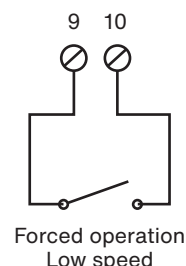

9.2. External control of high-speed forced operation (normal operation)

The external high-speed forced operation command (normal operation) forces the ventilation speed of the central ventilation unit to high speed, regardless of the operating speed requested by the time schedule and regardless of the status of the external low-speed forced operation command. The external high-speed forced operation command (normal operation) has priority over the time schedule and the external low-speed forced operation command (reduced operation). If the central ventilation unit is switched off by the time schedule, the activation of the external forced high-speed command (normal operation) will force the unit to start up at high speed.

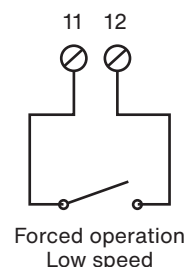

9.3. External shutdown control

The external shutdown control forces the central ventilation unit to shut down, regardless of the operating mode requested by the time schedule and regardless of the status of the external forced operation commands for reduced or normal operation.

The use of isolation registers on the supply and extract air circuits is highly recommended in case of repeated starting and stopping of the ventilation unit.

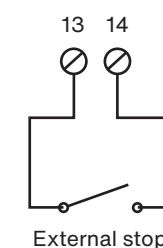

9.4. External fire protection control

When the external fire protection control is activated, the central ventilation unit operates in fire protection mode, regardless of the operating mode requested by the time schedule and regardless of the status of the external forced operation controls for reduced or normal operation. The fire protection mode has priority over all other operating modes.

The operation of the machine depends on the function settings made by the user. By default, the function is inactive when the equipment leaves the factory.

The potential of terminal (+C) is available on terminals (9), (11) and (13) of the customer's terminal block.

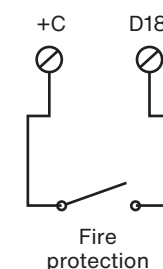

9.5. Motorised supply air register control (MSR)

The motorised supply air register can be supplied as an option. It is powered directly from the controller's DO1 output (24V AC). It has a safety return spring that ensures the register closes in the event of a power failure.

Installation and electrical connection are the responsibility of the installer.

The use of isolation registers on the supply and extract air circuits is highly recommended in case of repeated starting and stopping of the ventilation unit.

When the ventilation unit is in operation, there is a voltage of 24V AC between terminals (35) and (DO1). When idle, there is no voltage.

If the system is required to comply with the requirements of VDI 6022 and if the system needs to be shut down, the ventilation system (of which this unit is a part) must be completed with an additional damper on the fresh air inlet side, in order to meet the requirements. This damper must comply with at least air tightness class 2 of standard EN 1751 and must be insulated (double casing with intermediate insulation). This type of damper is not available as an option.

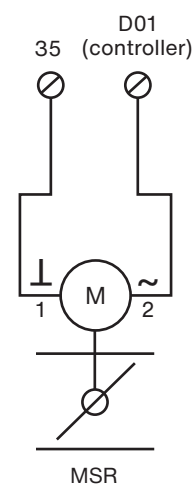

Cable colours:
1 = black
2 = red

9.6. Motorised exhaust air register control (MER)

The motorised exhaust air register can be supplied as an option. It is powered directly from the controller's DO2 output (24V AC). It has a safety return spring that ensures the register closes in the event of a power failure.

Installation and electrical connection are the responsibility of the installer.

The use of isolation registers on the supply and extract air circuits is highly recommended in case of repeated starting and stopping of the ventilation unit.

When the ventilation unit is in operation, there is a voltage of 24V AC between terminals (36) and (DO2). When idle, there is no voltage.

If the system is required to comply with the requirements of VDI 6022 and if the system needs to be shut down, the ventilation system (of which this unit is a part) must be completed with an additional damper on the fresh air inlet side, in order to meet the requirements. This damper must comply with at least air tightness class 2 of standard EN 1751 and must be insulated (double casing with intermediate insulation). This type of damper is not available as an option.

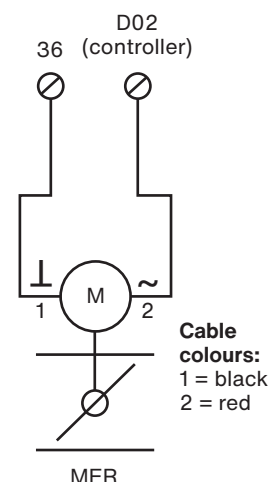

9.7. Night cooling signal (LOBBY)

The night cooling function takes advantage of the cooler outside temperatures at night to lower the internal temperature of the building and thus improve daytime comfort while limiting the energy consumption of any cooling systems. When the function is active, the aim is to maximise the airflow to make the most of the free cooling energy available outside.

For this function to be fully functional when the fans are regulated at constant pressure (LOBBY), it is necessary to be able to force the opening of the registers in the network, otherwise the air volume will be limited to an average value.

A 24V AC output (to be relayed) is provided between the terminals (22) of the customer terminal block and DO7 of the controller to force the opening of the zone registers during the night cooling period. When the function is active, there is a voltage of 24V AC between terminal (22) of the terminal block and (DO7) of the controller. When idle, there is no voltage.

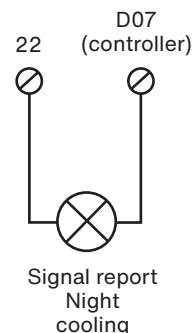

9.8. Alarm signal

The output contact is polarised at 24V AC and is programmed as NO at the factory:

No alarm or class C alarm (warning) (See alarm table)	Class A or B alarm is active (See alarm table)
No voltage between terminal block (20) and (DO5) of the controller	24V AC voltage between terminal terminal block (20) and (DO5) of the controller

The alarm signal is limited to 100mA. Under no circumstances should it be used to supply a consumer directly. The signal must be relayed.

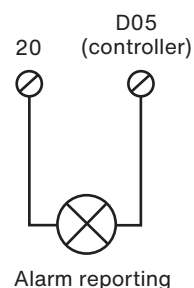

9.9. Remote fire stop - RFS

The dry NC (normally closed) contact of the RFS (or CMSI) must be connected by the installer between terminals (1) and (2) of the customer terminal block after having removed the shunt installed at the factory on these 2 terminals.

Opening the circuit cuts off the general 24V AC power supply to the entire control unit.

The ventilation unit is immediately stopped and the isolation registers (if present) are closed by their automatic return spring.

The unit restarts automatically as soon as the circuit is closed (closing of the RFS or CMSI contact).

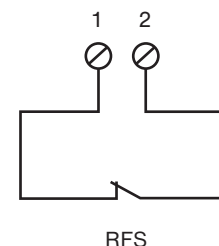

9.10. Autonomous trigger detector - ATD

The dry NC (normally closed) contact of the ATD must be connected by the installer between terminals (3) and (4) of the customer terminal block after having removed the shunt installed at the factory on these 2 terminals.

Opening the circuit cuts off the general 24V AC power supply to the entire control unit.

The ventilation unit is immediately stopped and the isolation registers (if present) are closed by their automatic return spring.

The unit restarts automatically as soon as the circuit is closed (closing of the ATD contact).

If an ATD is installed, a motorised register with a safety return spring should be fitted downstream of the intake air filters.

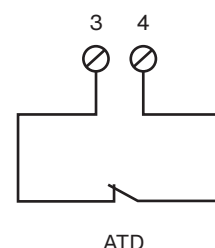

10. Connection of remote coils in ducts

The entire Zehnder Silvertop range can be combined with the Combi Box range in order to extend the basic functionality, particularly in cases where remote cooling coils are to be added to the duct system.

10.1. Remote hot water coil

When a remote hot water coil is used (available as an option in the Combi Box), the following accessories must be connected:

- 3-way valve (available as an option)
- The THA frost protection thermostat (available as an option)
- The pump (circulator) for the irrigation of the coil (selection and supply the responsibility of the installer)

It is also necessary to move the ventilation supply air temperature sensor (SSG) downstream of the remote hot water coil.

The installation must comply with the following hydraulic connection principle:

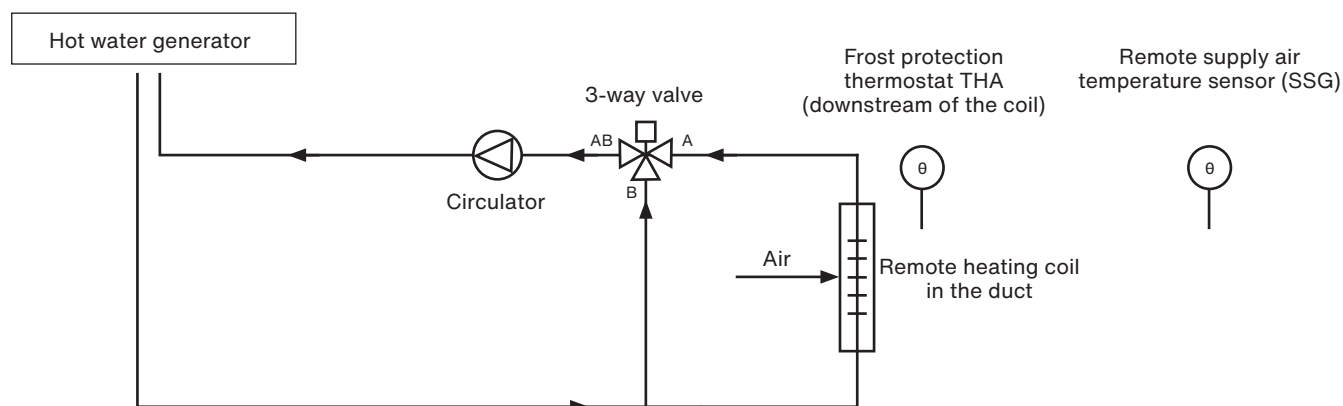

The hydraulic connection and installation of the hot 3-way valve must meet the following requirements:

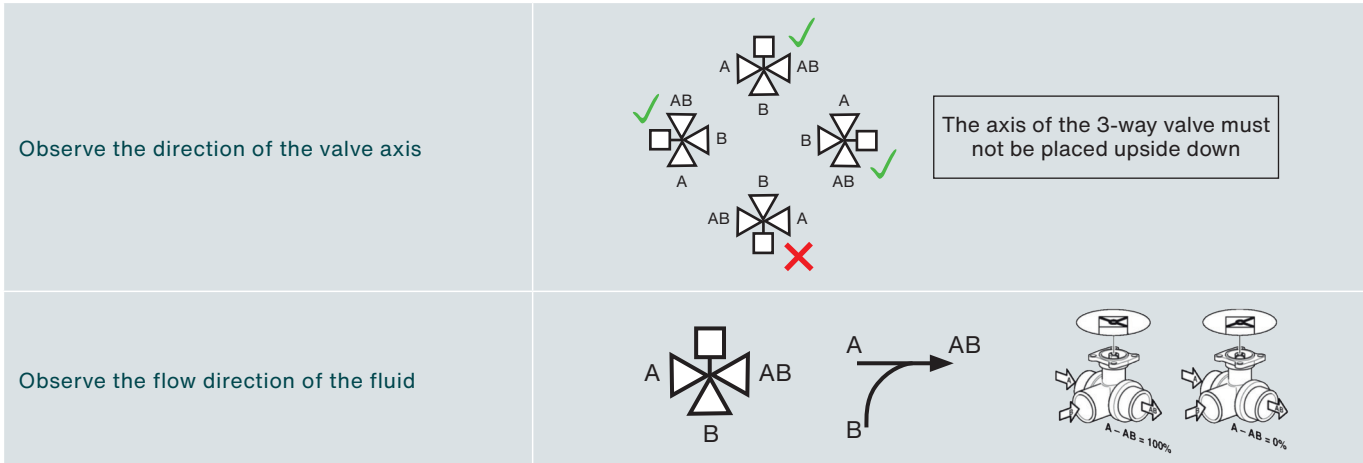

The electrical connection must meet the following requirements:

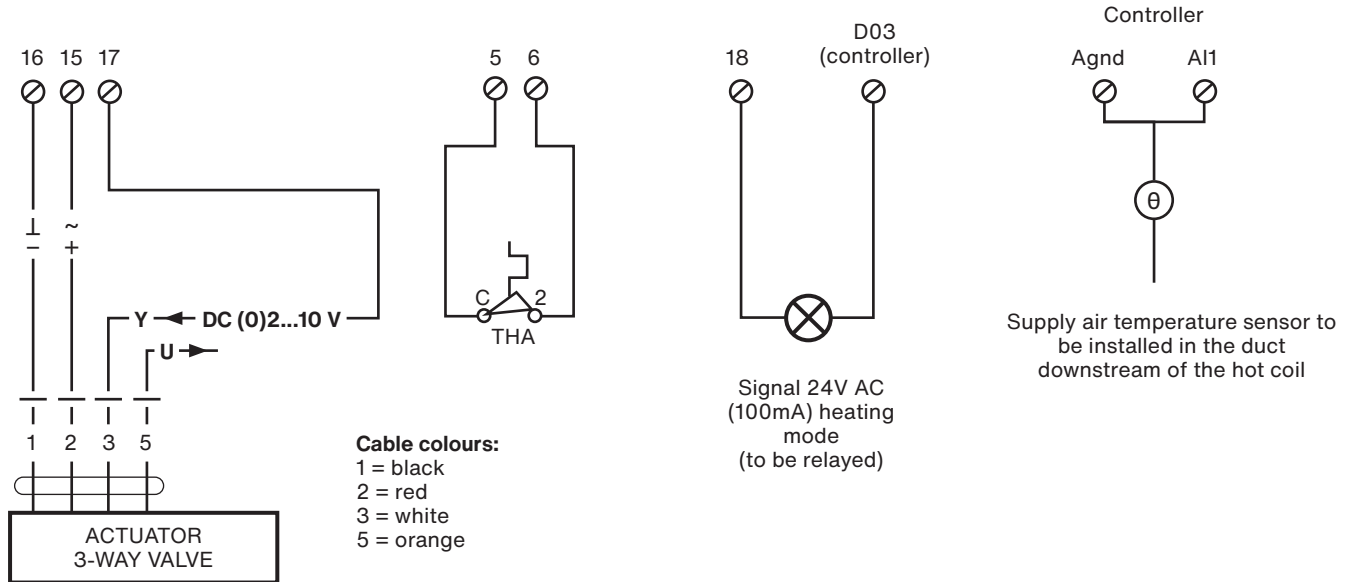

The THA frost protection thermostat is of the NC (normally closed) type. It should be set to +5 °C. It is closed when the bulb temperature is above +5 °C and opens when the temperature drops below +5 °C. Its function is to protect the coil from freezing. When the contact opens, the controller stops the ventilation. When the temperature rises, the controller restarts the fans. As long as the contact is open, the controller displays the alarm (56). This alarm is stored in the alarm history and is automatically acknowledged when the contact closes.

Please note that the “heating mode” signal is a control signal and not a power signal. Therefore, it must not be used as a power supply and must be relayed. The signal sent by the controller is 24V AC (100mA max).

10.2. Remote cold water coil

When a remote cold water coil is used (available as an option in Combi Box), it is necessary to connect the 3-way valve (available as an option) to the controller of the ventilation unit.

The coil circulator is the responsibility of the installer.

It is also necessary to move the ventilation supply air temperature sensor (SSG) downstream of the remote cold water coil.

The installation must comply with the following hydraulic connection:

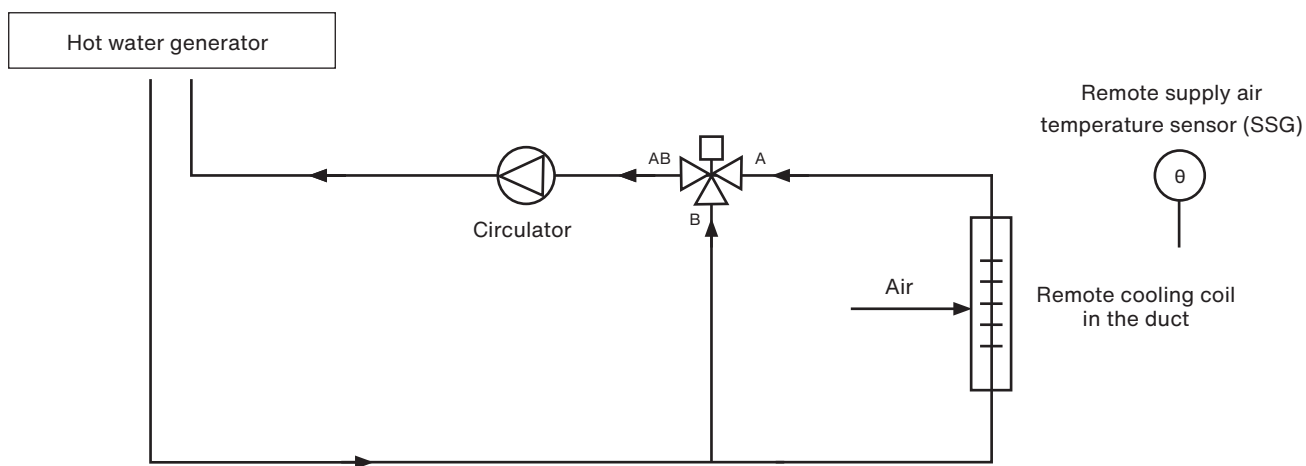

The hydraulic connection and installation of the 3-way valve must meet the following requirements:

<p>Observe the direction of the valve axis</p>	<p>The axis of the 3-way valve must not be placed upside down</p>
<p>Observe the flow direction of the fluid</p>	

The electrical connection must meet the following requirements:

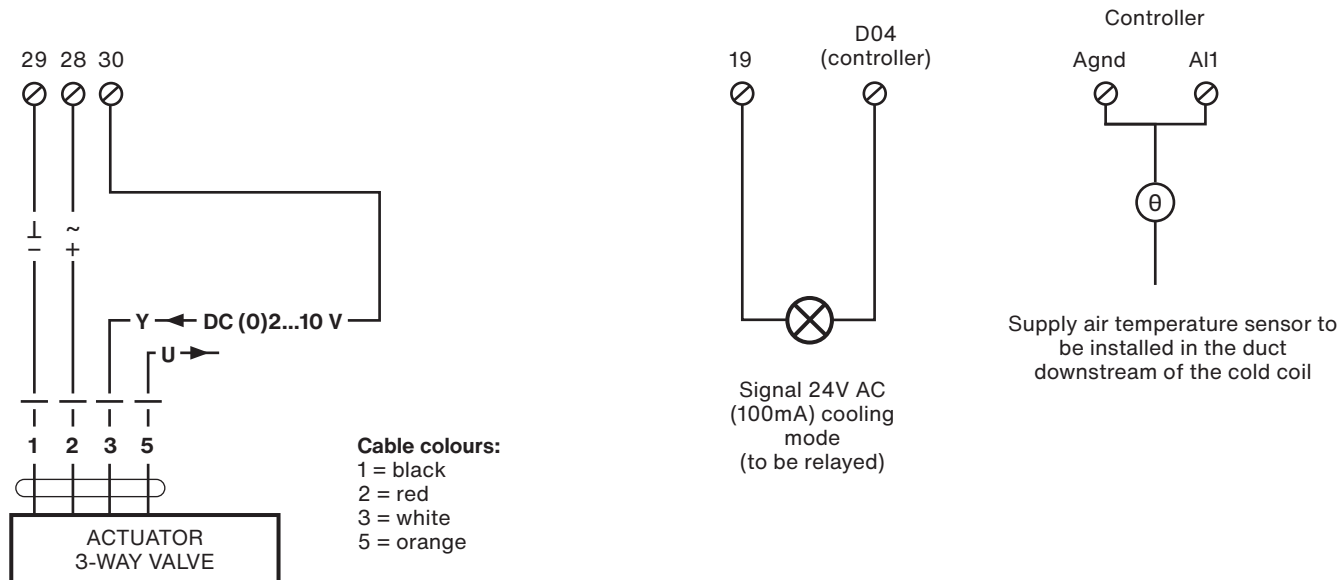

Please note that the “cooling mode” signal is a control signal and not a power signal. Therefore, it must not be used as a power supply and must be relayed. The signal sent by the controller is 24V AC (100 mA max).

10.3. Remote changeover coil (CO coil)

When a remote changeover coil is used (available as an option in Combi Box), it is necessary to connect the 3-way valve (available as an option) and the changeover thermostat to the controller of the central ventilation unit.

The changeover coil circulator is the responsibility of the installer.

It is also necessary to move the supply air temperature sensor (SSG) downstream of the remote changeover coil.

The changeover thermostat allows the control of the mixing valve to be reversed depending on the temperature of the fluid measured at the mixing valve inlet. It should be installed in the water supply line of the CO coil, upstream of the 3-way valve.

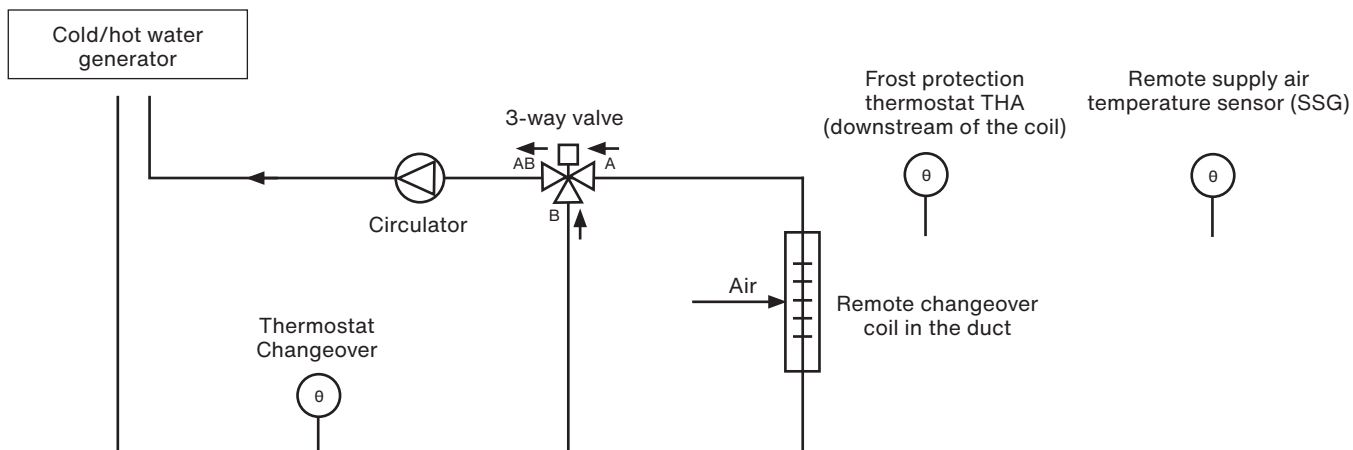

Electrical connection of the actuator to the changeover thermostat		
Changeover thermostat side	Terminal block and actuator side	
	Red wire	Y (control signal) of the actuator
	Brown wire	17 (heating signal)
	Black wire	30 (cooling signal)

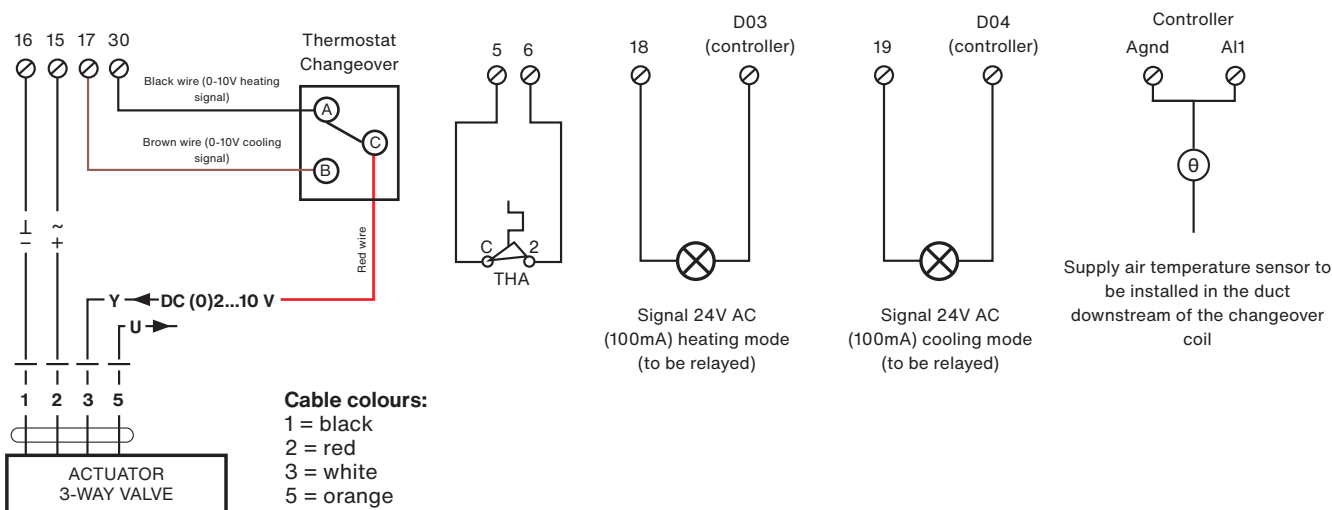

The behaviour of the changeover thermostat is defined in the table below:

$T \geq 30\text{ }^{\circ}\text{C} \pm 4\text{ }^{\circ}\text{C}$	$T \leq 15\text{ }^{\circ}\text{C} \pm 4\text{ }^{\circ}\text{C}$
Contact C-A open (C-B closed)	Contact C-A closed (C-B open)

Please note that the “cooling mode” and “heating mode” signals are control signals and not power signals. Therefore, they must not be used as a power supply and must be relayed. The signal sent by the controller is 24V AC (100 mA max).

10.4. Remote direct expansion (DX) cooling/heating/reversible coil

The control of a direct expansion (DX) coil is described in a separate document and is independent of this manual. Please contact your supplier.

11. General functions

11.1. Installation of the thermal sequence

Initialisation at start-up allows the unit to be started at an operating point that is as close as possible to the one that will be recalculated during operation in order to avoid any source of discomfort and unnecessary energy consumption.

The initialisation of the thermal sequence at start-up depends on the outdoor temperature measured at the time the machine is started:

Outdoor temperature < +3 °C	Outdoor temperature ≥ +3 °C
<p>The unit starts when 100% heat is required*.</p> <p>As long as the feedback signal of the supply air fan is idle**, the electric heating coil is not activated.</p>	<p>The unit starts with maximum energy recovery.</p>

* The control output of the 3-way valve or the control output of the electric heating coil is at 100% (10V).

** ECO/DIVA: the DEP S pressure switch contact is open; LOBBY: the pressure signal is below the minimum threshold; MAC2/QUATTRO: the volume signal is below the minimum threshold.

11.2. Start-up sequence

The start-up sequence is activated when the following conditions are met:

- The unit is ON
- There are no active class A alarms (alarms that shut down the unit) or the external control is not active
- At least one time programme (reduced operation or normal operation) is active, or a forced operation (normal operation or reduced operation) is active, or the fire protection function set to start the unit is active, or there is a request for operation from the BMS.

The start-up sequence takes a total of 120 seconds. During this time, the alarms are disabled (except for the THS electric coil overheating alarm (63), which is monitored during this period) and the AHU starts up at the operating point defined at the initialisation of the thermal sequences at start-up. The minimum fan control signal does not apply.

The openings of the intake air and exhaust air registers open as soon as the start sequence is activated.

The control signal for the extract fan is enabled 15 seconds after the start sequence is activated.

15 seconds later, the control signal for the extract air fan is enabled and the extract air fan starts.

The outputs for controlling the 3-way valves and the heating or cooling pumps are activated.

Once the 120 seconds have elapsed, the fan unit switches to normal mode at the end of the start-up sequence.

The minimum and maximum fan control signal is then taken into account and the alarm monitoring function is activated.

In the event of a power failure, the unit will automatically restart as soon as the power supply is restored.

11.3. Shutdown sequence (post-ventilation)

The shutdown sequence occurs when at least one of the following conditions is met:

- Appearance of an alarm whose action requires the normal shutdown of the unit (note that some alarms are programmed for rapid shutdown, in which case the shutdown sequence is ignored and the unit shuts down immediately)
- The unit is switched to OFF
- No active time slot
- The fire function is set to stop the unit
- Stop request from the BMS
- External stop request to digital input DI

The shutdown sequence lasts for a time related to the setting of the fan shutdown time limits (post-ventilation) and the intake air and exhaust air register closing time limits. When the shutdown sequence is initiated, the alarm management function and the hot/cold outputs are immediately deactivated. The supply fan is switched off after 180 seconds. The extract fan is switched off 30 seconds later. The intake air and exhaust air registers close after 5s following the fan shutdown and all actuator control signals are deactivated.

12. Starting up

The Zehnder Silvertop ventilation unit is delivered pre-set and ready to use.

However, if the factory settings do not meet the requirements, the specific actions to be taken are:

- Installation and electrical wiring of optional extras
- Controller date and time setting
- Setting the summer/winter time changeover (automatic changeover by default)
- Time schedule settings
- Fan setpoint setting
- Temperature setpoint setting
- Communication protocol setting (if communication used)
- Setting of specific functions (according to version and need):
 - Night cooling: activation time and fan setpoint offset
 - Fire protection
 - Icing protection by reducing the airflow rate

By using the save user settings function at the end of the commissioning process, a normally functional configuration can be restored at any time.

13. Maintenance

13.1. Annual general quality check

Check the ducts, flexible sleeves and anti-vibration pads and replace them if necessary.

Check that all the components connected to the control unit are in place so that no vibrations can be transferred to external items.

Check the electrical connections and the tightness of the terminals.

13.2. Filter quality check

Classification		Cleaning* (Water + gentle detergent)	Extraction* Supply*
Filtration efficiency ISO 16890	Reference		
ePM10 - 50%	M5	Restricted (1 to 4 times)	YES
ePM10 - 55%	F7	NO	

*Filter cleaning must be carried out with care to avoid damaging the filter media.

Only F5 filters can be blown out and cleaned with care.

Frequency (in months of operation)	
Every 3 months (to be adapted according to local conditions)	Every 12 months
Verification (Cleaning if necessary for M5 filters)	Filter replacement

13.3. Removal and installation of the exchanger condensate tray

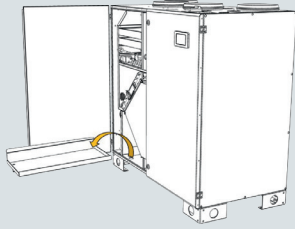
Step	Removal	
D1	Stop the machine and cut off the power supply using the isolating switch on top of the machine.	
D2	Remove the condensate drain attached to the drain connection of the condensate tray under the machine.	
D3	Open the left-hand door.	
D4	Remove the condensate tray from its housing.	
Step	Installation	
R1	Proceed in the reverse order to the removal process, taking care not to damage the panel feed-through seal and ensuring that the connection between the condensate drain tray spigot and the syphon piping is sealed.	
R2	Fill the condensate tray with water to fill the syphon.	
R3	Start the machine. Check for condensate or air leaks.	

The condensate tray can be cleaned and disinfected by soaking and rinsing with clean water, if necessary with bleach.

13.4. Removal and installation of the plate heat exchanger

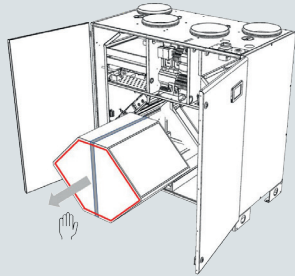
Step	Removal	
D1	Stop the machine and cut off the power supply using the isolating switch on top of the machine.	
D2	Open the 2 service doors.	
D3	Remove the exchanger by pulling on its carrying strap, taking care not to damage the heat exchange surfaces of the exchanger, which could impair the performance of the machine.	
D4	Place the exchanger on a clean, dust-free surface, protected from any impact that could cause damage. Cover it with a protective film if it is to be stored for a long time or if there is to be work in the vicinity that is likely to produce dust. Identify the direction of assembly to be observed for reassembly.	
Step	Installation	
R1	Proceed in the reverse order to the removal process, taking care to respect the direction of assembly of the exchanger and checking the integrity of the seals placed on each side. Replace them if necessary.	
R2	Check the syphon for water and refill if necessary.	
R3	Start the machine. Check that there is no abnormal noise and that the performance and setpoints (pressure, volume flow, temperature, etc. depending on the version) are achieved.	

The exchanger can be cleaned by rinsing with clean water, if necessary using a spray. Allow sufficient time for drainage and drying to prevent water droplets from entering the supply air system.

14. Troubleshooting - maintenance

When the ventilation unit is malfunctioning, it is recommended that you first:

- Check the tightness and connection of the terminal blocks and electrical plugs
- Check the setting and consistency of the control parameters and setpoints.

14.1. Connection and setting of the filter control pressure switch

Pressure switches for monitoring the clogging of filters allow the degree of clogging in filters to be checked by measuring the pressure drop between the inlet (upstream) and the outlet (downstream) of the filter. When the pressure drop (pressure difference) of the filter element exceeds the setting of the pressure switch, the NO contact of the pressure switch closes. The factory setting of the filter pressure switch is 150 Pa for M5 filters and 200 Pa for F7 filters. If an additional filter is installed for the intake air (double filter stage) in addition to the standard filter, the pressure switch must be set to 300 Pa.

Refer to the wiring diagram for details on the electrical connection of the pressure switches.

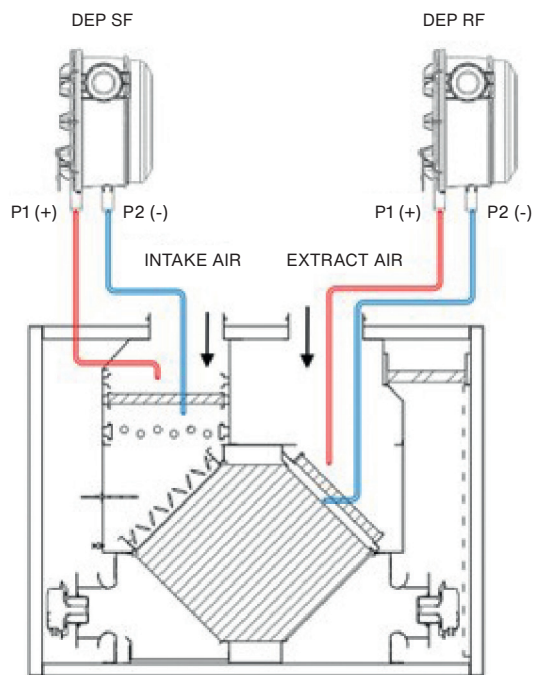

14.2. Connection and setting of the fan feedback pressure switches (ECO and DIVA)

The fan operation control pressure switches allow the pressure difference between the fan inlet and outlet to be monitored at any time, thus indicating whether the fan is operating correctly or not.

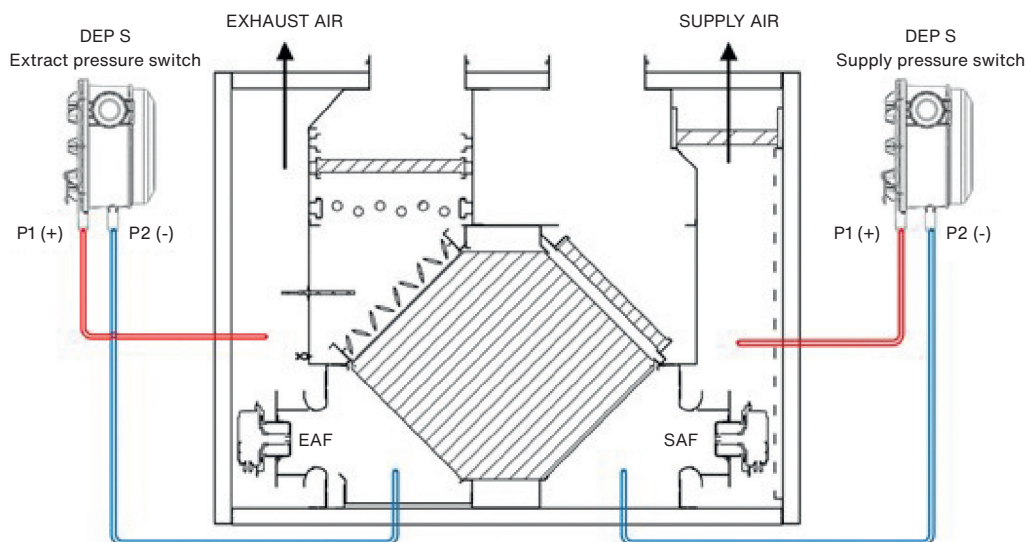

The factory setting for the pressure switches is 25 Pa.

Refer to the wiring diagram for details on the electrical connection of the pressure switches.

14.3. Connection and setting of pressure transducers (LOBBY)

The pressure transducers convert the relative air pressure measured at the air supply and extract of the unit into an analogue 0-10V signal which is transmitted to the controller.

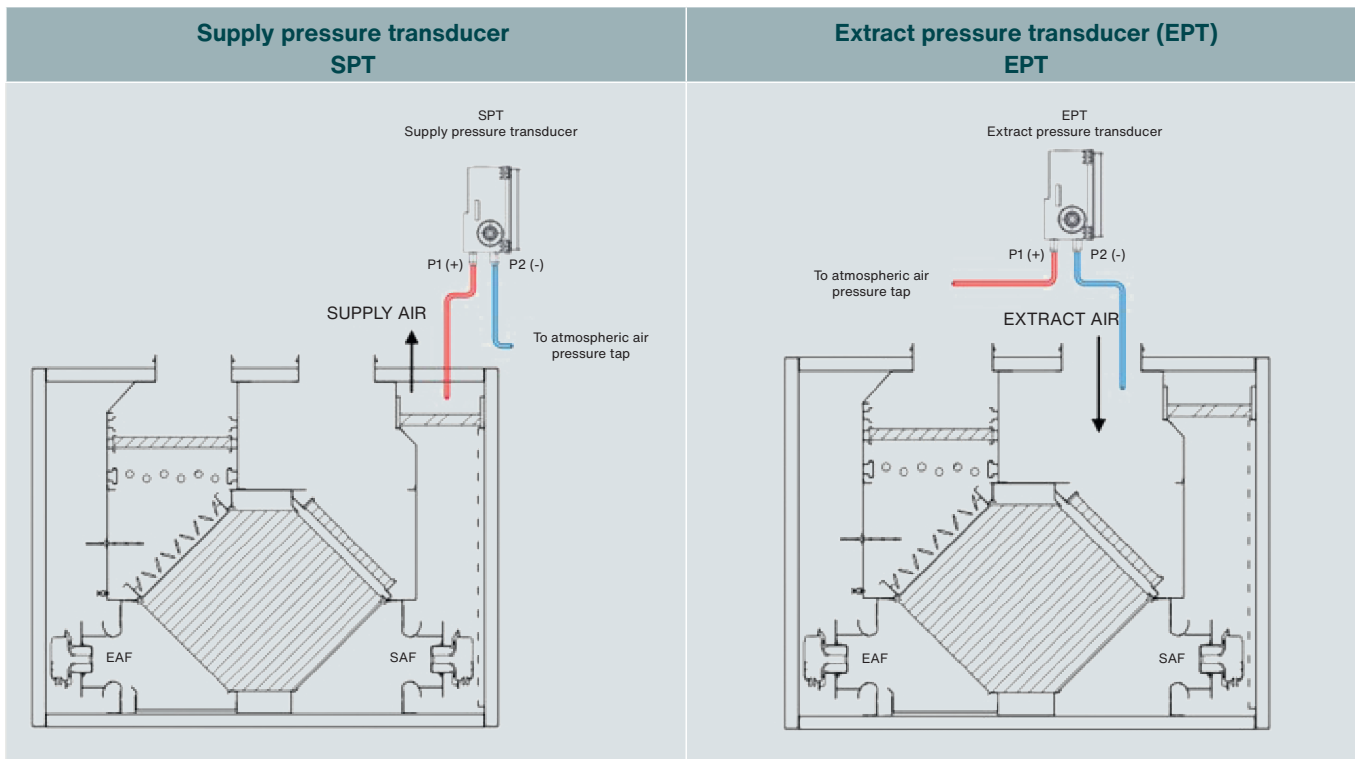

The pressure signal is also used by the controller to check that the fans are working properly. The threshold is 25 Pa.

The factory setting is 130 Pa.

Refer to the electrical diagram (see chapter 15 Electrical control wiring diagram) for details of the electrical connection of the pressure transducers.

ZEHNDER SILVERTOP LOBBY					Setting the position of the pressure transducer jumpers
Gauge	15	23	35	52	
SPT	0-1600 Pa / 0-10 V				<p>ON</p> <p>The jumpers are in the OFF position (position 0)</p>
EPT					

14.4. Connection and setting of pressure transducers (MAC2 and QUATTRO)

The pressure transducers convert the differential air pressure measured into an analogue 0-10V signal, which is transmitted to the controller. This signal is then converted by the controller into a volume signal.

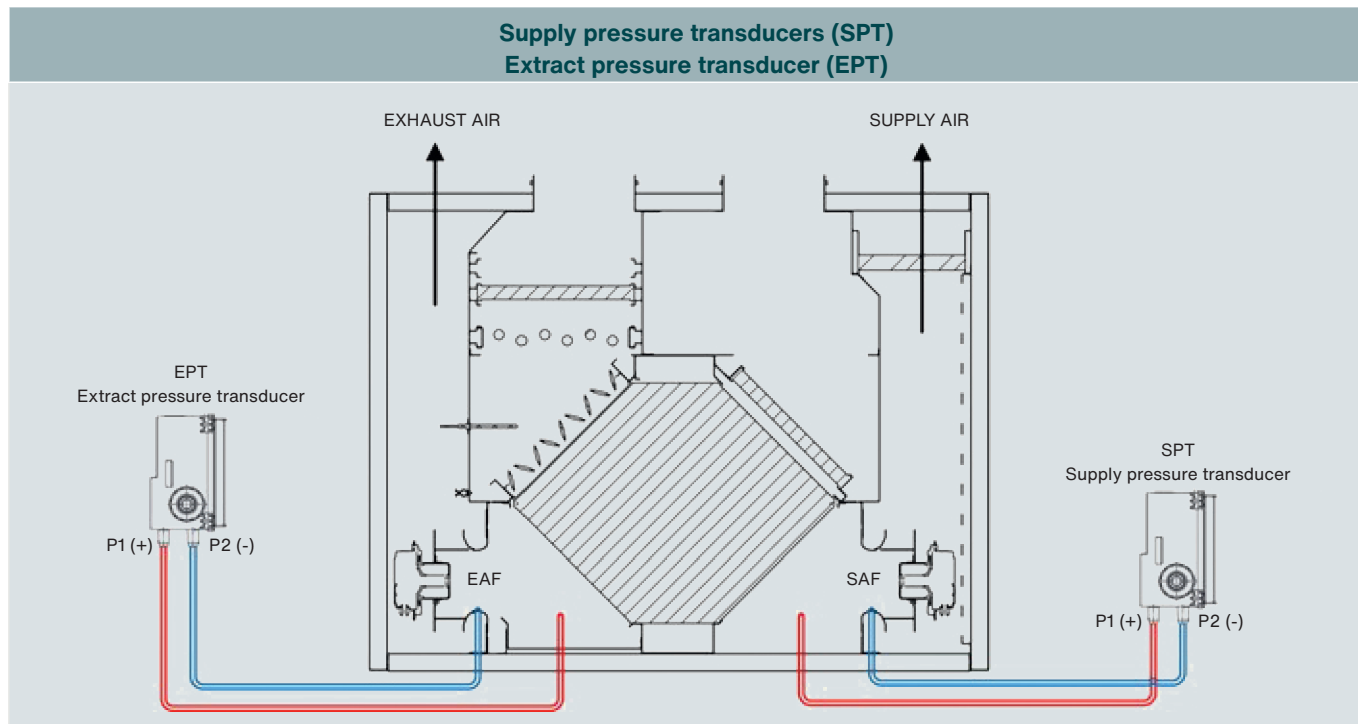

For the MAC2 and QUATTRO versions, the P1(+) pressure switch pressure tap must be connected upstream of the fan bell, and P2(-) must be connected directly to the inlet ring.

		ZEHNDER SILVERTOP MAC2 / QUATTRO				Setting the position of the pressure transducer jumpers
Gauge	15	23	35	52		
SPT	0-1600 Pa / 0-10 V					
EPT						

The signal is also used by the controller to check that the fans are working properly (run and deviation monitoring). The threshold is different for each machine model:

Machine (MAC2 or QUATTRO)	Reduced operation volume	Normal operation volume	S + R fan difference threshold	S + R fan difference threshold
Zehnder Silvertop 15	800 m ³ /h	1200 m ³ /h	300 m ³ /h	360 m ³ /h
Zehnder Silvertop 23	1000 m ³ /h	1800 m ³ /h	350 m ³ /h	540 m ³ /h
Zehnder Silvertop 35	1700 m ³ /h	3000 m ³ /h	610 m ³ /h	900 m ³ /h
Zehnder Silvertop 52	2750 m ³ /h	3900 m ³ /h	740 m ³ /h	1170 m ³ /h

Refer to the electrical diagram (see chapter 15 Electrical control wiring diagram) for details of the electrical connection of the pressure transducers.

14.5. Overheating safety thermostats THS and THSD

The overheating safety thermostats are placed directly:

- On the electric heating coil (EHC) for the THS
- On the electric intake air preheating coil (EDC) for the THSD

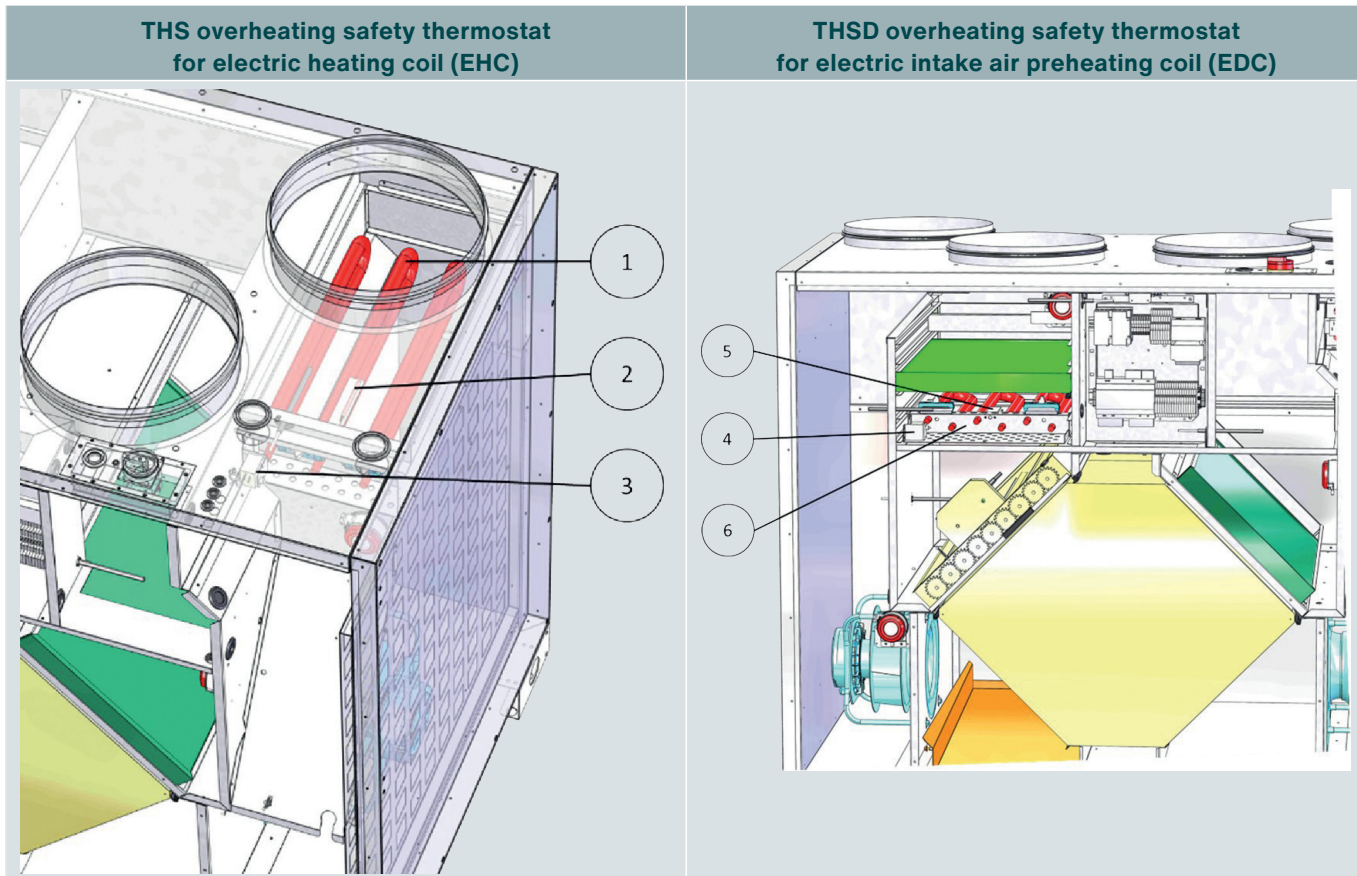

Reference points:

- 1- Electric heating coil (EHC)
- 2- Safety thermostat bulb (THS)
- 3- Overheating safety thermostat (THS) for electric heating coil
- 4- Overheating safety thermostat (THSD) for electric defrosting coil
- 5- Safety thermostat bulb (THS)
- 6- Electric defrosting coil (EDC)

When overheating has been detected by the THS or THSD overheating safety thermostats, it is necessary to reset them by pressing the white reset button after removing the protective cap screwed on the thermostat body itself.

Before resetting the thermostat, it is necessary to know the cause of the overheating and to remedy it in order to avoid any damage to the equipment. There may be overheating of the electric coil, for example, due to a faulty solid state relay and/or fan, or due to a power failure when the coil was at full power (check for alarms).

14.6. Replacing the internal memory battery

The appearance of the low battery alarm (alarm #78) indicates that the battery powering the internal memory and Real Time Clock (RTC) is too low and may fail to operate in the event of a power failure.

The procedure for replacing the battery is described below. A condenser takes over when the battery is removed. The battery should be replaced within approximately 10 minutes after the power supply is cut off.

If the battery replacement takes less than 10 minutes, it will not be necessary to reload the programme and the clock will continue to operate normally. If necessary, the controller must be reprogrammed.

It is a CR2032 battery.

Press the clips on either side of the housing with a small screwdriver to release the cover from the base. Hold the base and remove the cover.

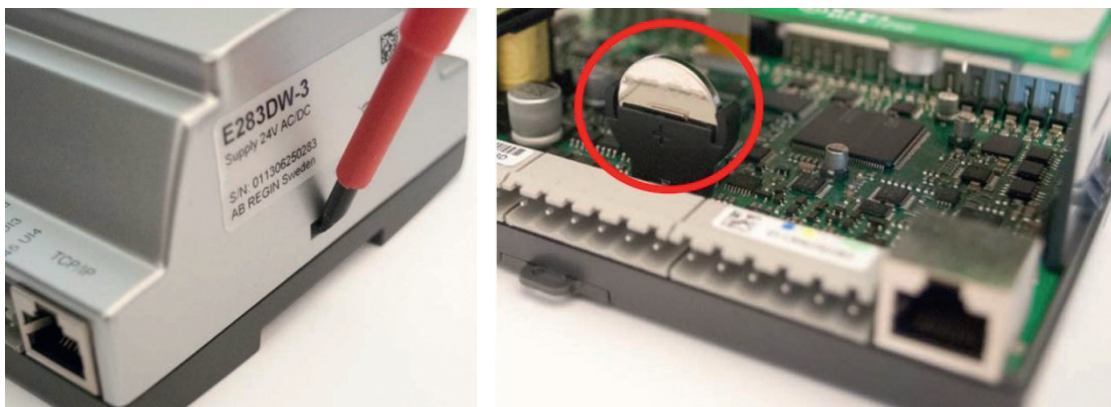

Hold the battery and gently pull it upwards until it comes out of the battery holder.

Replace the new battery by pressing firmly on it to slide it into its holder.

Note: Pay attention to the direction of the battery to ensure correct polarity.

15. Electrical control wiring diagram

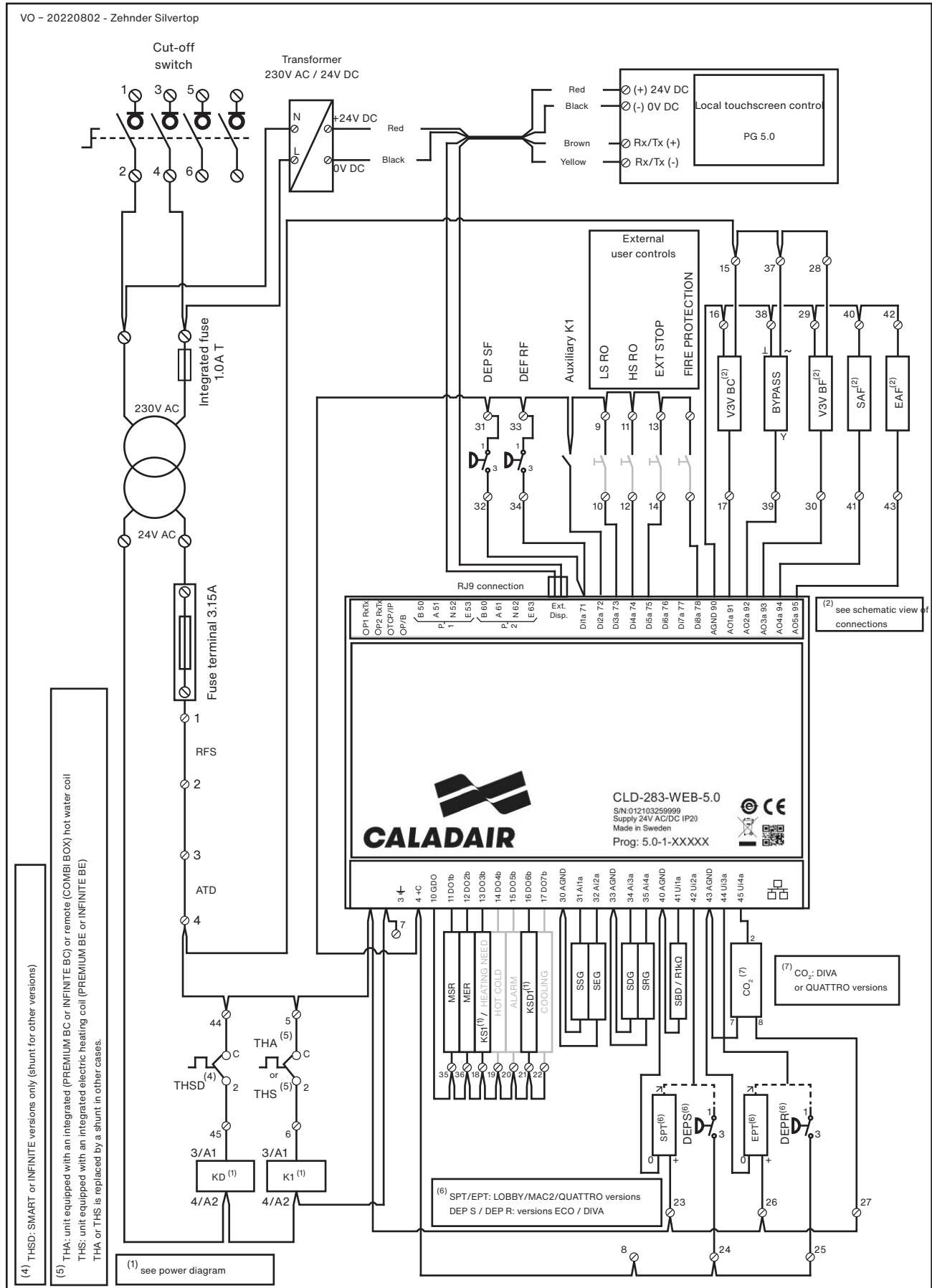

Standard equipment (depending on unit version)		
BYPASS	Control signal for bypass recovery actuator	All versions
DEP SF	Supply filter pressure switch	All versions
DEP RF	Extract filter pressure switch	Optional, factory-wired
Auxiliary K1	Auxiliary contact of contact transmitter K1	All versions
SAF	Control signal for supply fan	All versions
EAF	Control signal for extract fan	All versions
THA	Frost protection thermostat	If equipped with a hot water coil (PREMIUM BC / INFINITE BC), or control of a remote water coil in the Combi Box duct
THS	Overheating safety thermostat for electric heating coil	If equipped with an electric heating coil (PREMIUM BE / INFINITE BE)
THSD	Overheating safety thermostat for electric defrosting coil	If equipped with an electric defrosting coil (SMART / INFINITE)
KD	Electric defrosting coil contact transmitter (EDC)	
KSD1	Defrosting coil static relay (EDC)	If equipped with an electric defrosting coil (SMART / INFINITE) single-phase 230V AC or three-phase 400V AC
KSD2	Defrosting coil static relay (EDC)	If equipped with a three-phase 400V AC electric defrosting coil (SMART / INFINITE)
K1	Electric heating coil (EHC) contact transmitter	
KS1	Static relay for electric heating coil (EHC)	If equipped with an electric heating coil (PREMIUM BE / INFINITE BE) single-phase 230V AC or three-phase 400V AC
KS2	Static relay for electric heating coil (EHC)	If equipped with an electric heating coil (PREMIUM BE / INFINITE BE) three-phase 400V AC
BE	Electric heating coil	If equipped with an electric heating coil (PREMIUM BE / INFINITE BE)
EDC	Electric defrosting coil	If equipped with an electric defrosting coil (SMART / INFINITE)
SSG	Supply temperature sensor	All versions Equipped with a yellow sleeve
SEG	Outdoor temperature sensor	All versions Equipped with a blue sleeve
SDG	Defrosting temperature sensor (exhaust air)	All versions Equipped with a brown sleeve
SRG	Extract temperature sensor	All versions Equipped with a black sleeve
SBD	Defrost coil temperature sensor (preheated intake air)	If equipped with a defrosting coil (SMART / INFINITE) Equipped with a red sleeve
R1kΩ	1k Ohm resistance	If not equipped with an EDC defrosting coil (FIRST/ PREMIUM)

Standard equipment (depending on unit version)		
CO ₂	CO ₂ sensor	DIVA / QUATTRO
DEP S	Pressure switch for supply fan operation (SAF)	ECO / DIVA
DEP R	Pressure switch for extract fan operation (EAF)	ECO / DIVA
TRP S	Supply air pressure transducer	LOBBY / MAC2 / QUATTRO
TRP R	Extract air pressure transducer	LOBBY / MAC2 / QUATTRO

Optional equipment (to be wired on site according to user requirements)	
LS RO	External control of low-speed forced operation (reduced operation) by NO dry contact
HS RO	External control of high-speed forced operation (normal operation) by NO dry contact
EXT STOP	External control of unit shutdown via NO dry contact
RFS	Remote fire stop by NC dry contact
ATD	Autonomous trigger detector by NC dry contact
ALARM	Polarised 24V AC digital on/off output for alarm signal
COOLING (NIGHT COOLING)	Polarised 24V AC digital on/off output for active night cooling signal
HEATING NEED	Polarised 24V AC digital on/off output for active heating need
COOLING NEED	Polarised 24V AC digital on/off output for active cooling need
MSR	Output for controlling the opening of the motorised supply register polarised at 24V AC
MER	Output for controlling the opening of the motorised extract register polarised at 24V AC
V3V BC	0-10V control signal for the 3-way valve of the hot water heating coil (BC)
V3V BF	0-10V control signal for the 3-way valve of the cold water cooling coil (BF)

16. Electrical power wiring diagrams

16.1. Single-phase 230V AC electric heating and defrosting coils

Zehnder Silvertop	Versions included					
	FIRST	SMART	PREMIUM BE	PREMIUM BC	INFINITE BE	INFINITE BE
06		✓	✓		✓	✓
08		✓	✓		✓	✓
15			✓			

VO - 20211118 - Zehnder Silvertop

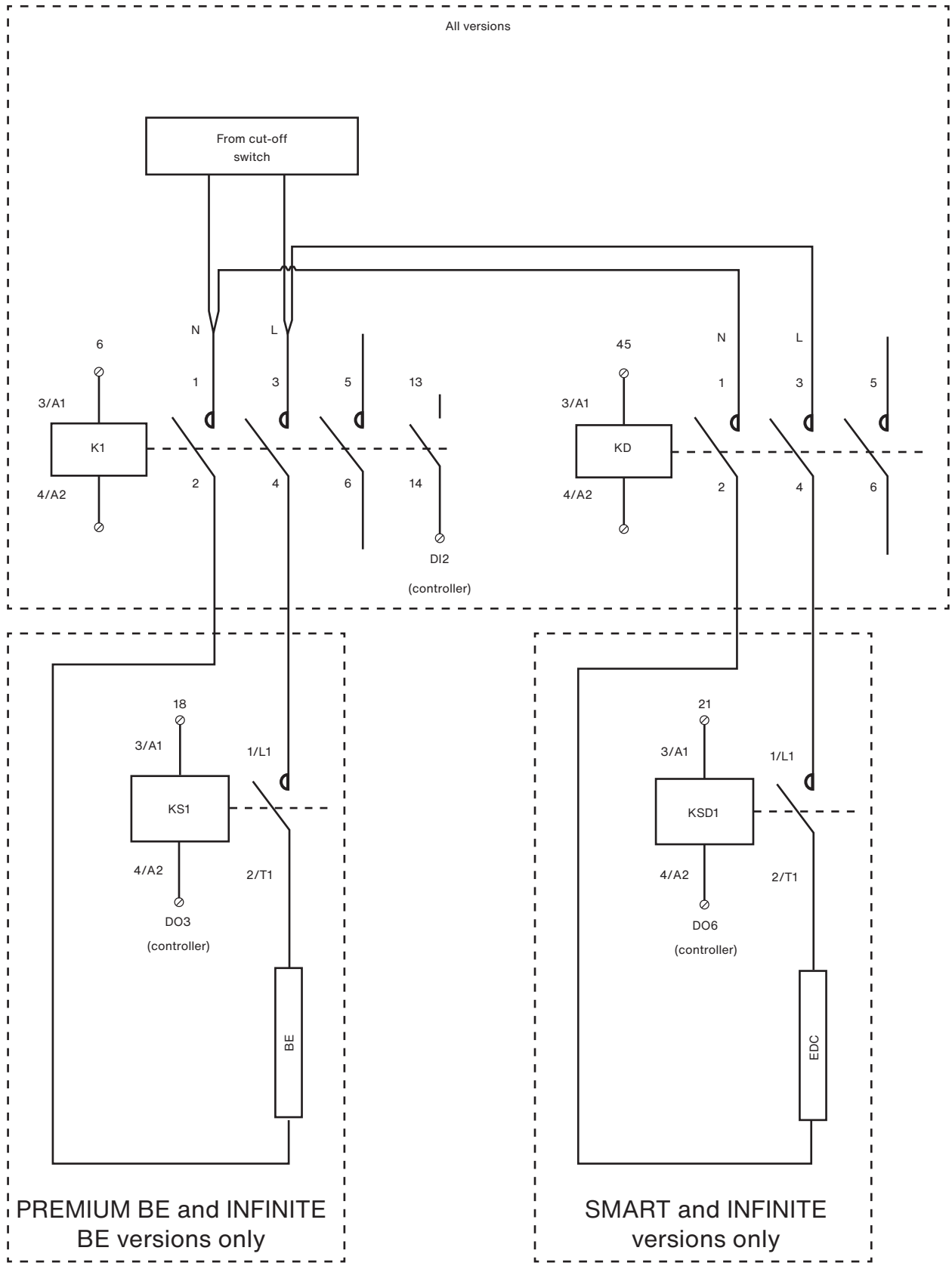

16.2. Three-phase 400V AC electric heating and defrosting coils

Zehnder Silvertop	Versions included					
	FIRST	SMART	PREMIUM BE	PREMIUM BC	INFINITE BE	INFINITE BC
15		✓			✓	✓
23		✓	✓		✓	✓
35		✓	✓		✓	✓
52		✓	✓		✓	✓

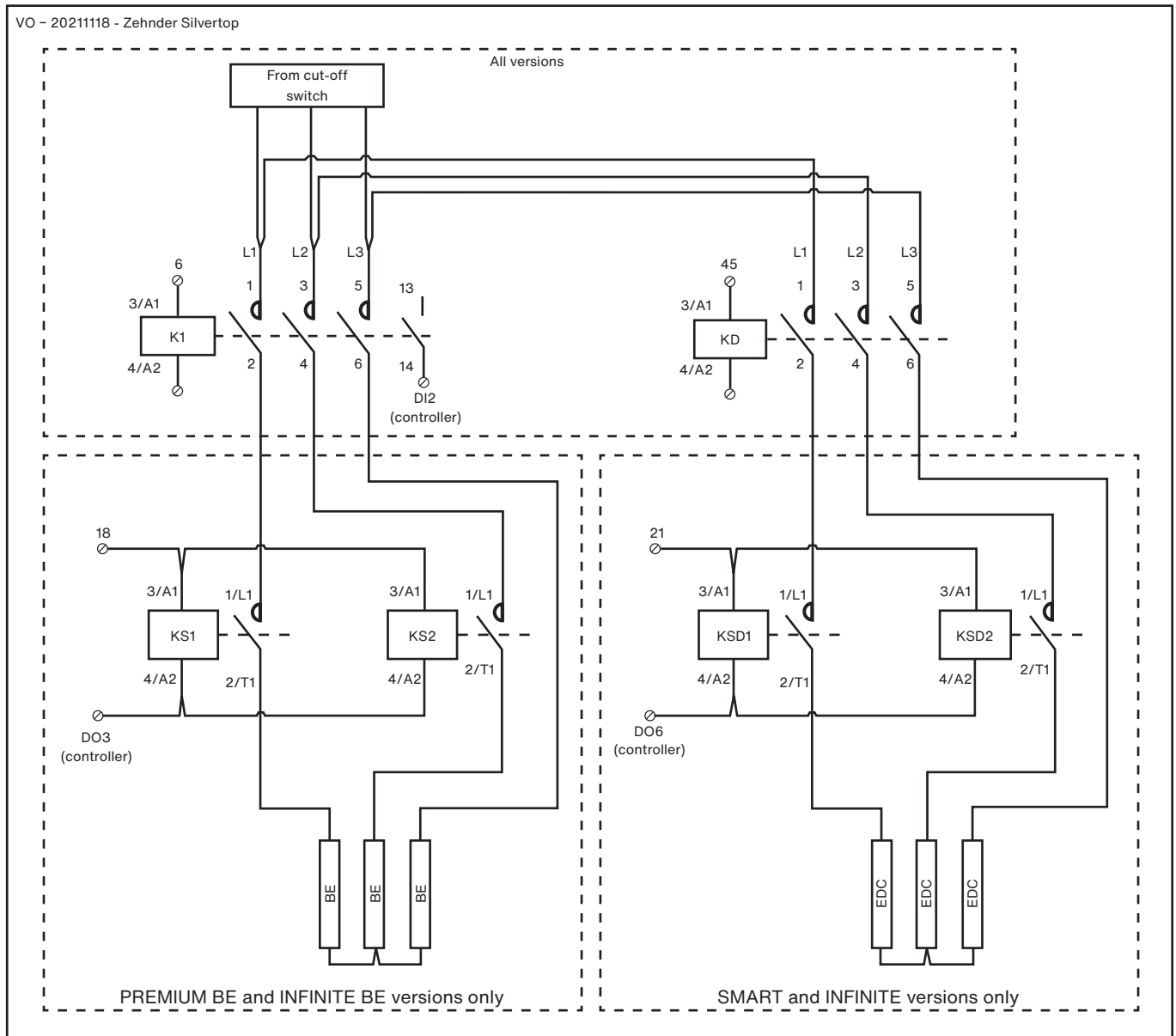

16.3. Motorised fans

Zehnder Silvertop 06-08 motors

*Fan power supply terminal block see 7.2 Electrical board.

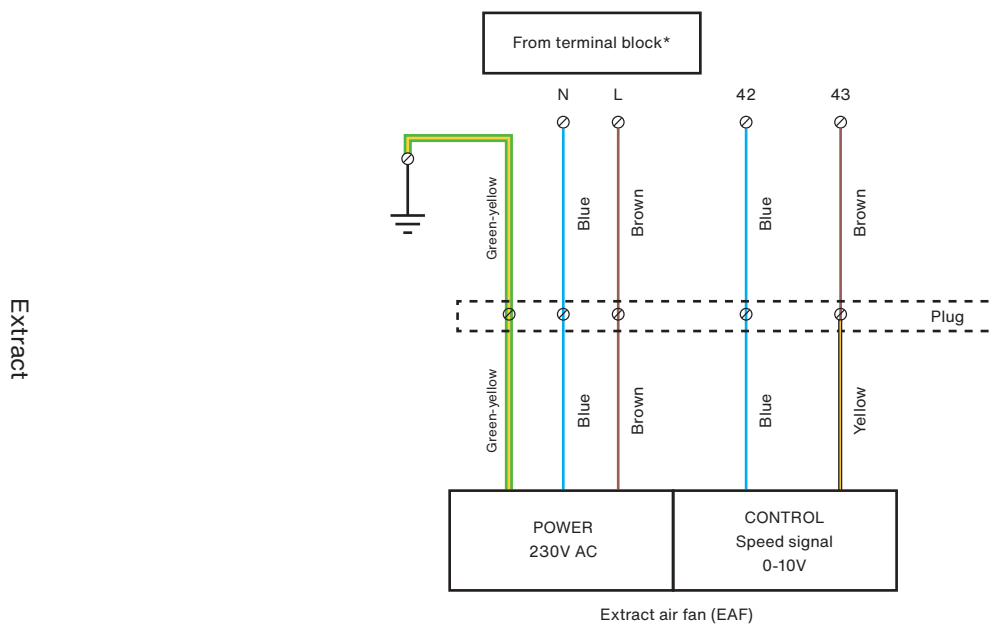
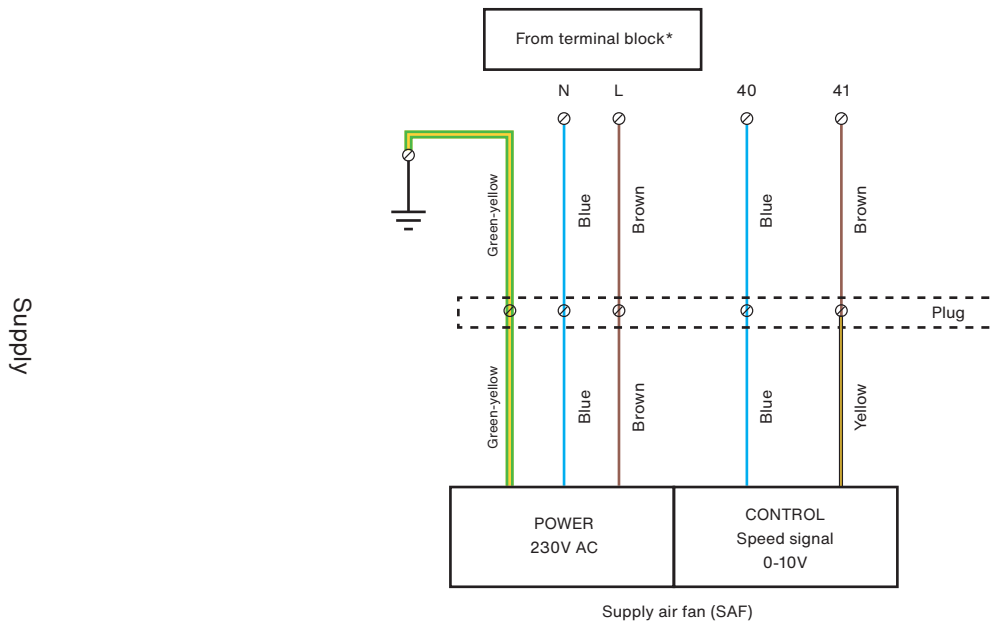

Zehnder Silvertop 15 motors

*Fan power supply terminal block see 7.2 Electrical board.

Supply

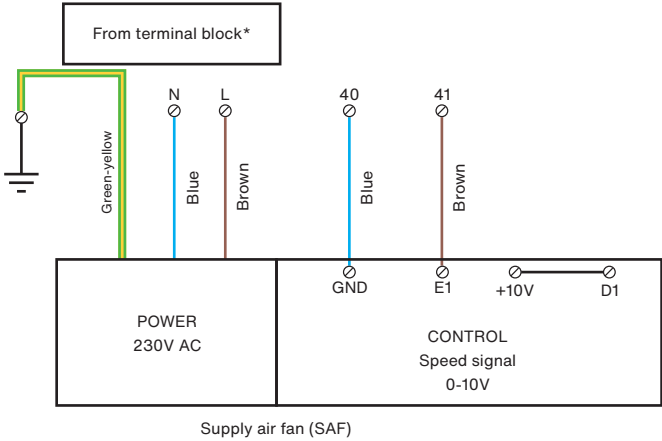

Extract

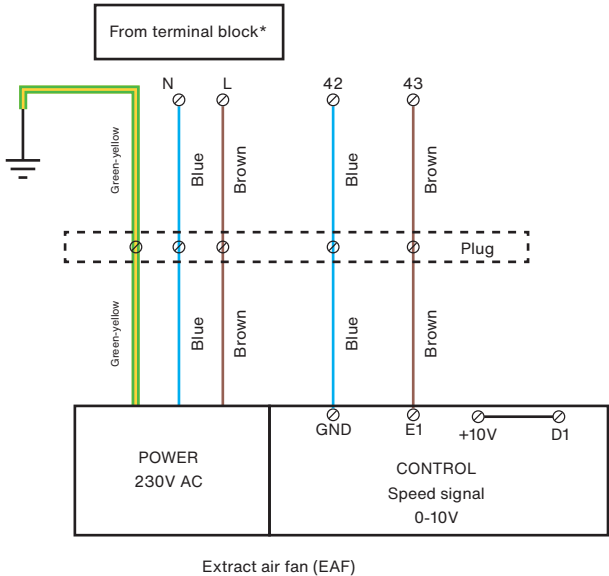

Zehnder Silvertop 23 motors

*Fan power supply terminal block see 7.2 Electrical board.

Supply

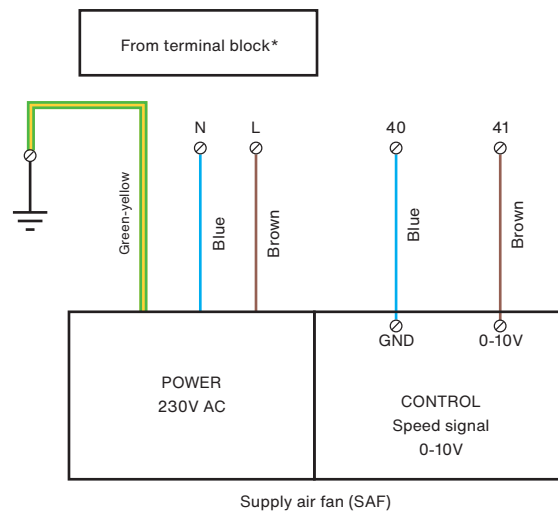

Extract

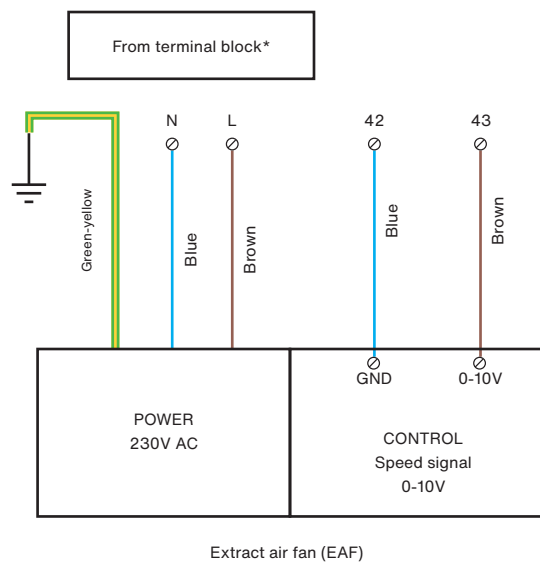

Zehnder Silvertop 35 motors

*Fan power supply terminal block see 7.2 Electrical board.

Supply

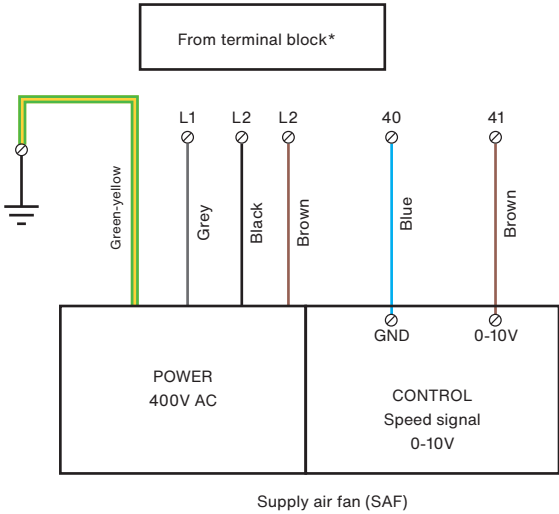

Extract

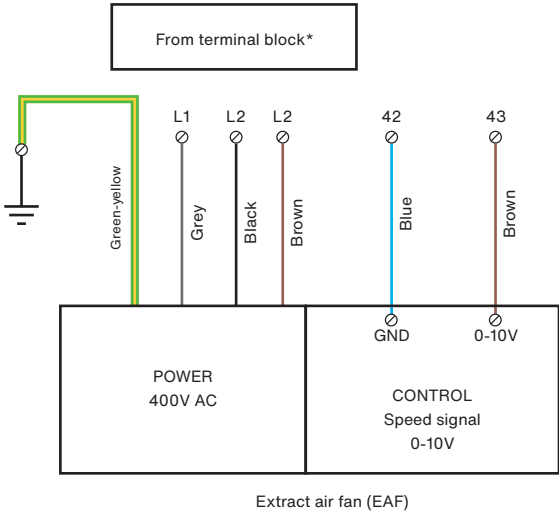

Zehnder Silvertop 52 motors

*Fan power supply terminal block see 7.2 Electrical board.

Supply

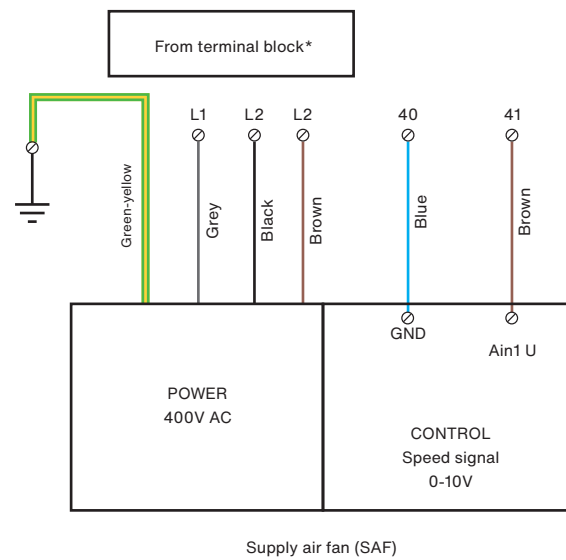

Extract

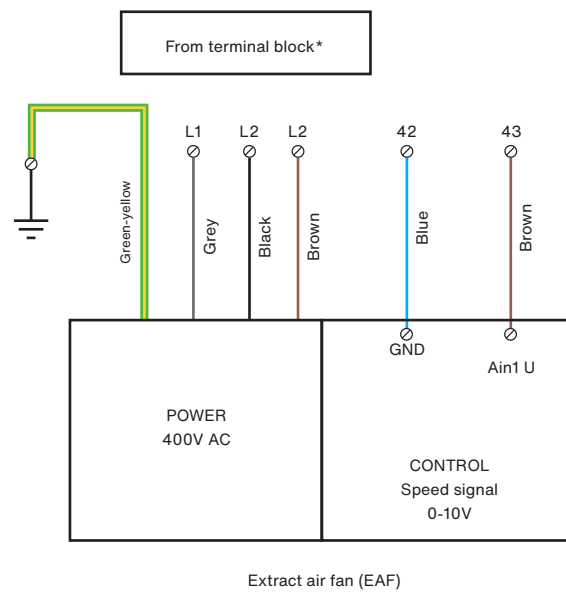

17. Zehnder Easy 5.0 controller

See specific manual Z-EN-Version-CSY-INM-Zehnder Easy 5.0.

18. SEASON controller

18.1. General

The SEASON controller is a simplified and streamlined solution for controlling the ventilation unit. In contrast to the Zehnder Easy 5.0 controller, it does not have an intelligent electronic controller, a local touch control PG 5.0 or a remote Zehnder EDT2 room touch control.

The SEASON controller includes as standard:

- Individual fan speed setting via adjustable potentiometer
- Heat recovery management by adjustable thermostat, including the functions:
 - Frost protection of the heat exchanger by bypassing the intake air flow in the case of a machine equipped with a plate heat exchanger.
 - Cold recovery, heat recovery
- Fan operation report via pressure switch (NO or NC dry contact)
- The report of the intake air filter clogging state (NO or NC dry contact)

The SEASON controller does not allow the control of heating or cooling coils.

The rotary exchanger or the bypass flap (in the case of a plate heat exchanger) operates in on-off mode.

18.2. Overview and construction

The overview and construction of the SEASON version is very similar to the basic ECO version. The differences are mainly in the electrical board and the components related to the control system (temperature sensors, controller). The SEASON version does not have a supply air heating coil or a intake air preheating coil.

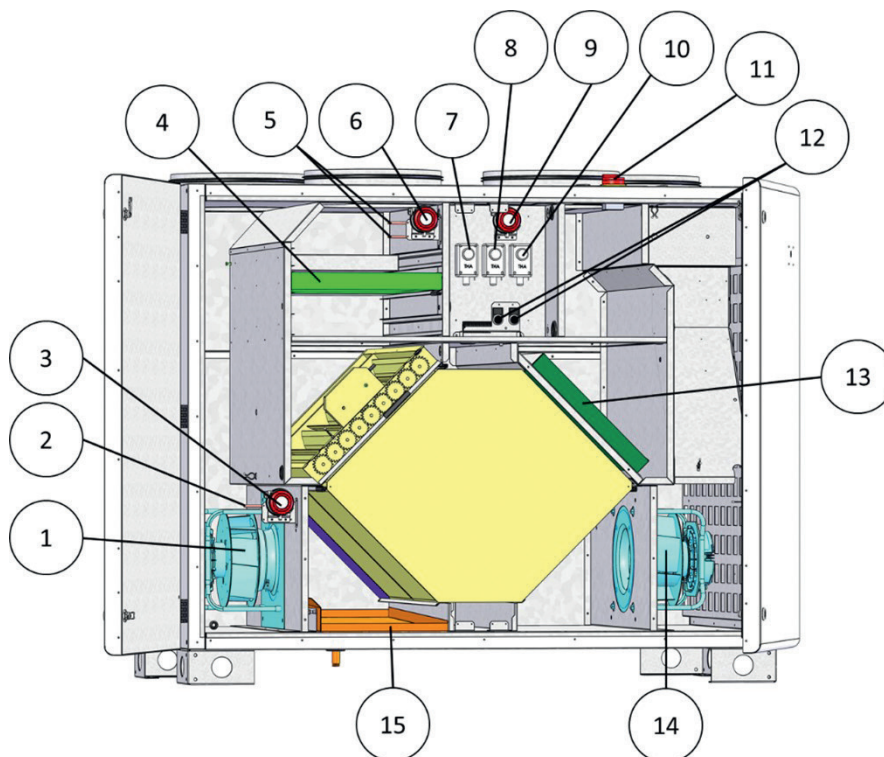

Reference point	Name	Component
1	EAF	Extract air fan
2		Control thermostat bulb TH3 (exhaust air temperature)
3	DEP R	Pressure switch for extract fan operation (EAF)
4	SF	Supply filter (intake air)
5		Thermostat bulbs TH1 and TH2 (outside air temperature)
6	DEP SF	Pressure switch to control the clogging of the intake air filter
7	TH1	Control thermostat TH1 (heat recovery)
8	TH2	Control thermostat TH2 (cold recovery)
9	DEP S	Pressure switch to control the operation of the supply fan (SAF)
10	TH3	Control thermostat TH3 (frost protection)
11	IG	Cut-off switch
12	POT SAF POT EAF	Setpoint potentiometers for supply air fan speed (SAF) and exhaust air fan speed (EAF)
13	RF	Extract filter
14	SAF	Supply air fan

The other components common to the standard range equipped with the Zehnder Easy 5.0 controller are presented in chapter 7.1 General overview of the unit.

18.3. Electrical compartments and user controls

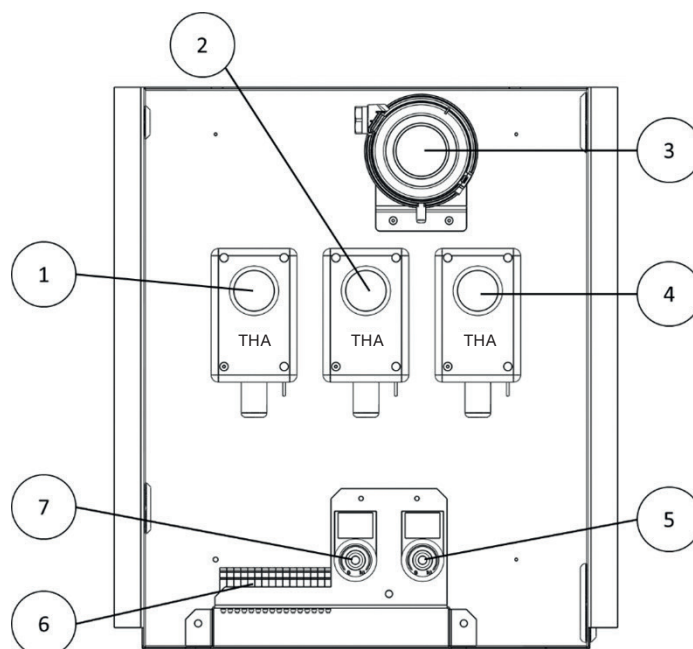

Reference point	Name	Component
1	TH1	Control thermostat TH1 (heat recovery)
2	TH2	Control thermostat TH2 (cold recovery)
3	DEP S	Pressure switch to control the operation of the supply fan (SAF)
4	TH3	Control thermostat TH3 (frost protection)
5	POT SAF	Potentiometer for air supply speed setting (SAF)
6		Electric terminal block
7	POT EAF	Potentiometer for air extract speed setting (EAF)

18.4. General operating principle

When the power is switched on (isolating switch in ON position), the supply fan and the extraction fan start after a few seconds to reach the set speed requested by the potentiometer position.

The bypass flap is activated when the power is switched on and depending on the outside air temperature, the exhaust temperature and the setting of the (adjustable) control thermostats.

	Exhaust temperature**	Outdoor air temperature**		
	< 5 °C	< 18 °C	18 °C...24 °C	> 24 °C
Bypass flap position*	Open	Closed (heat recovery)	Open	Closed (cold recovery)

*Open = the intake air flow does not pass through the exchanger / closed = the entire intake air flow passes through the exchanger

**Values for the factory settings of the thermostats to be adapted as required. Maintain a temperature difference of at least 6°C between the 2 thermostats.

***The thermostat placed at the exhaust (TH3) must be set at a temperature ≥ 5 °C.

18.5. User settings

18.5.1. Thermostat TH1 (heat recovery)

The TH1 thermostat bulb is placed in the intake air flow (= outdoor temperature).

Outdoor temperature < 18 °C	Outdoor temperature > 18 °C
Closed contact	Open contact

18.5.2. Thermostat TH2 (cold recovery)

The TH2 thermostat bulb is placed in the intake air flow (= outdoor temperature).

Outdoor temperature < 24°C	Outdoor temperature > 24°C
Open contact	Closed contact

18.5.3. Thermostat TH3 for frost protection



This thermostat ensures the frost protection function of the plate heat exchanger.

The bulb is placed in the exhaust air flow.

Outdoor temperature < 5 °C	Outdoor temperature > 5 °C
Open contact	Closed contact

18.6. Connecting and setting external user devices

At any time, the user can check the operating status of the fans and the state of clogging of the supply air filter through the use of 3 pressure switches:

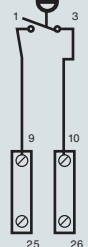
Device	Factory setting	Electrical connection responsibility of the user
Pressure switch to control the operation of the supply fan (SAF)	25 Pa	<p>DEP S</p>  <p>The connection is to be made directly to the device.</p>
Pressure switch to control the operation of the extract fan	25 Pa	<p>DEP R</p>  <p>The connection is to be made directly to the device.</p>
Pressure switch for clogging of the intake air filter	150 Pa M5 filters 200 Pa F7 filters	<p>DEP SF</p>  <p>The connection must be made between terminals (25) and (26).</p>

18.7. Troubleshooting and maintenance

As the SEASON control system is very simple, the risk of breakdowns is relatively limited and confined to the main components.

Fault	Possible causes
The supply air fan is not working	<p>The 0-10 V control signal potentiometer is in position 0 or is defective (control signal at the motor input below 1 V).</p> <p>The 0-10 V control signal wire is defective or the signal polarity is reversed.</p> <p>The power supply wiring is defective.</p> <p>The motor is defective.</p>
The extract air fan is not working	<p>The 0-10 V control signal potentiometer is in position 0 or is defective (control signal at the motor input below 1 V).</p> <p>The 0-10 V control signal wire is defective or the signal polarity is reversed.</p> <p>The power supply wiring is defective.</p> <p>The motor is defective.</p>
The bypass flap is not working (plate heat exchanger) (the unit blows air at a temperature close to the outdoor temperature at low/high outdoor temperatures)	<p>The outdoor temperature is in the range where the bypass is inactive (normal case).</p> <p>Control thermostats TH1, TH2, TH3 are incorrectly set or defective.</p> <p>The actuator wiring is defective, the actuator is not powered.</p> <p>The actuator is defective.</p>

18.8. General SEASON wiring diagram

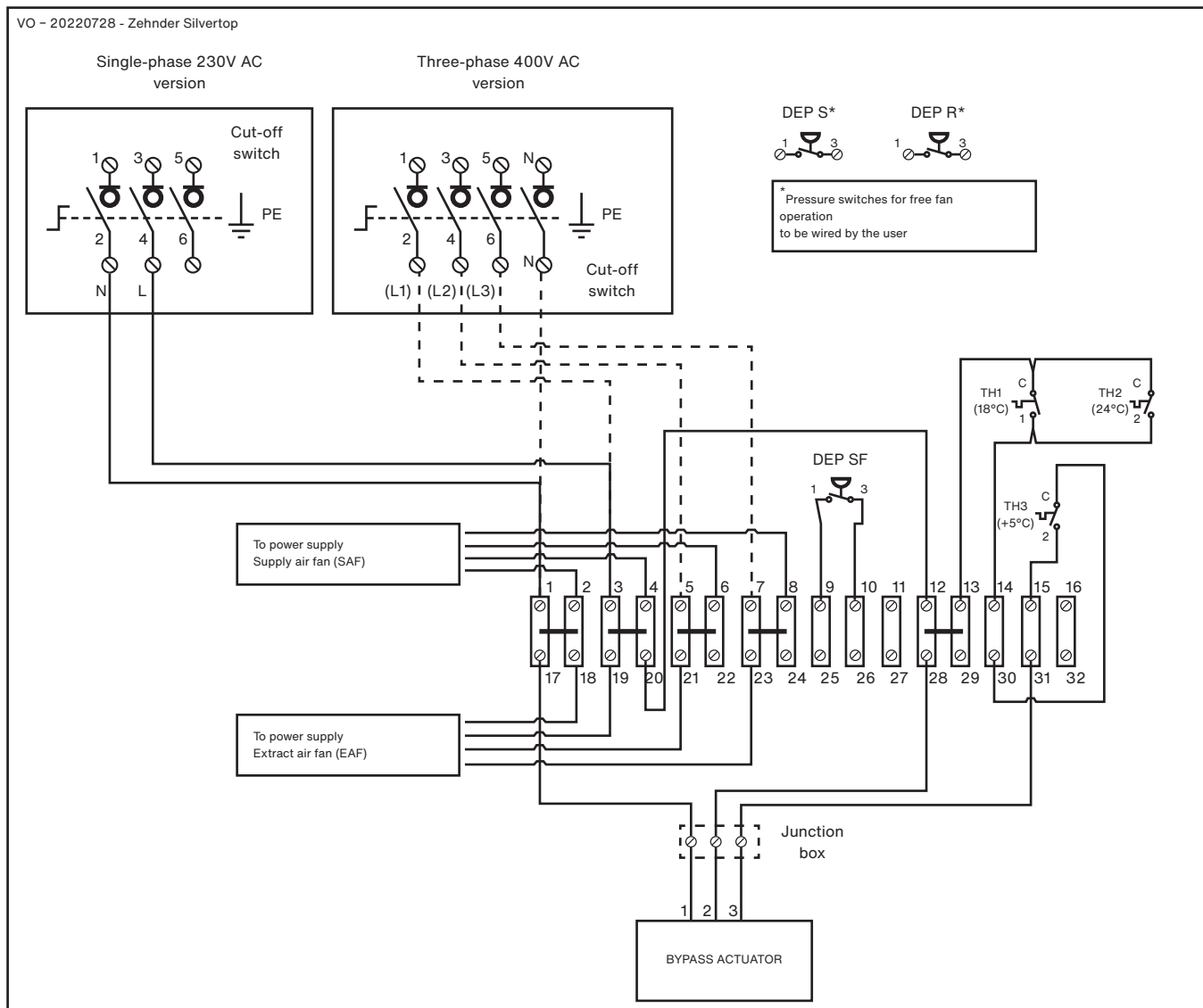

Note:

The power supply for the bypass actuator is provided between terminals (1) and (2) of the actuator.

When the power is supplied:

- The potential is absent in terminal (3) of the actuator, the actuator is open, the air is diverted from the exchanger and there is no energy recovery
- The potential is present at terminal (3) of the actuator, the actuator is closed, the air flows through the exchanger and energy recovery is active (100%).

18.9. Electrical wiring diagram for SEASON motorised fans

Zehnder Silvertop 06-08 motors

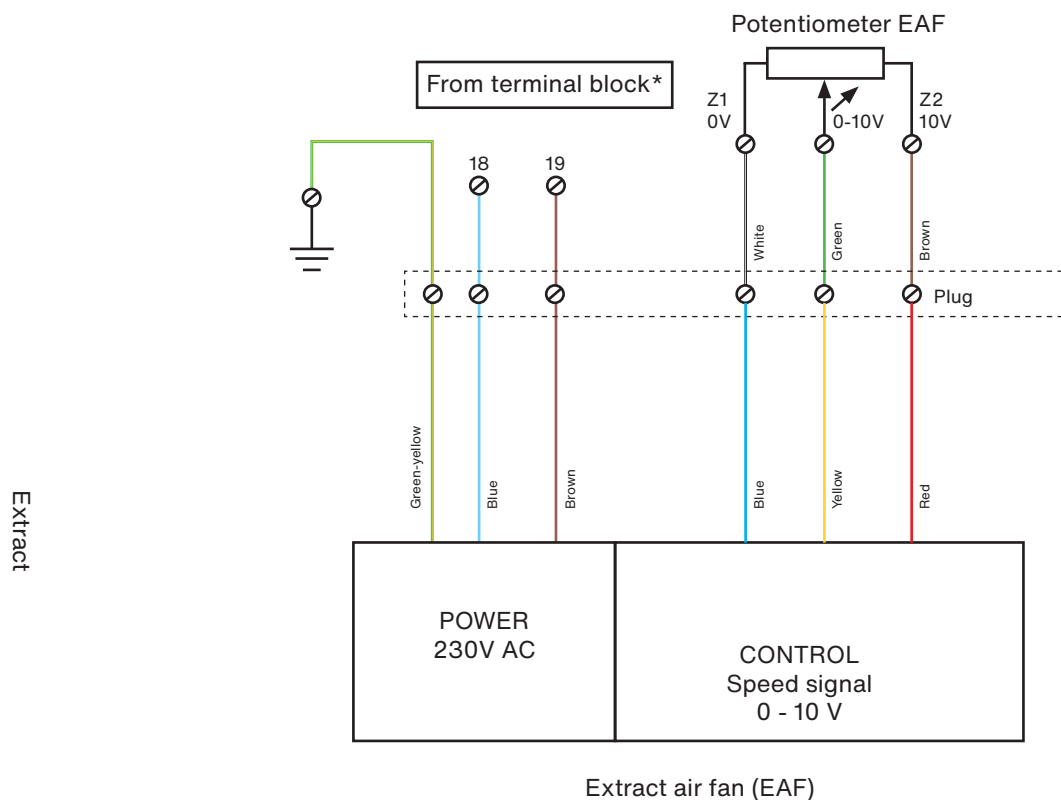
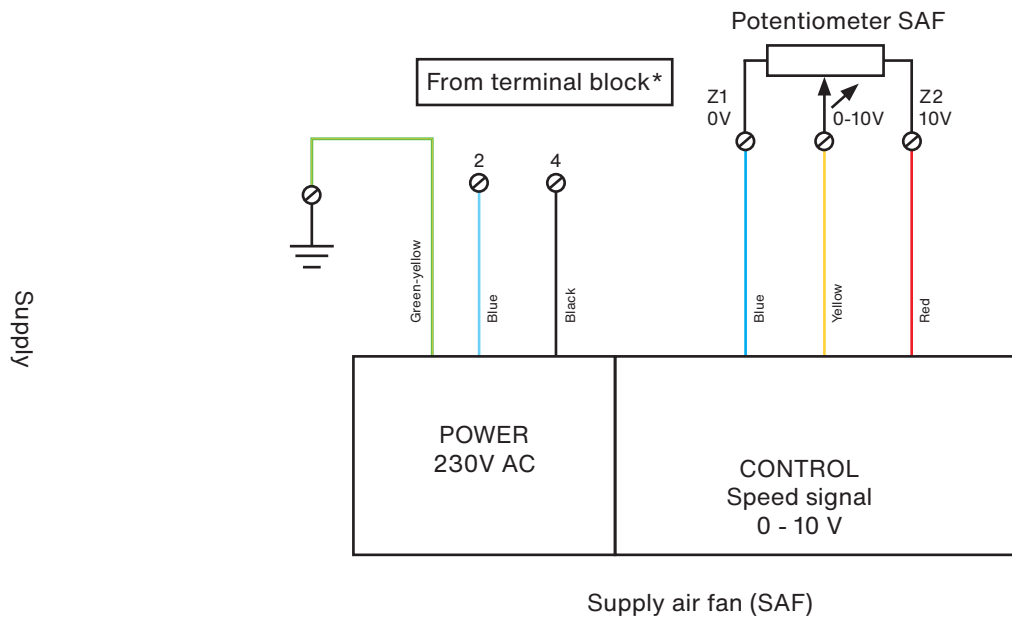

*Power supply terminal block see chapter 18.3 Electrical compartments and user controls.

Zehnder Silvertop 15 motors

Supply

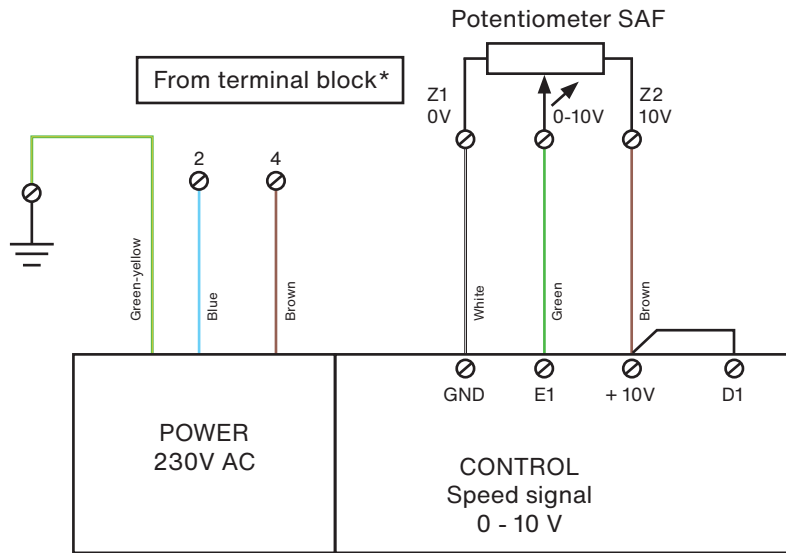

Supply air fan (SAF)

Extract

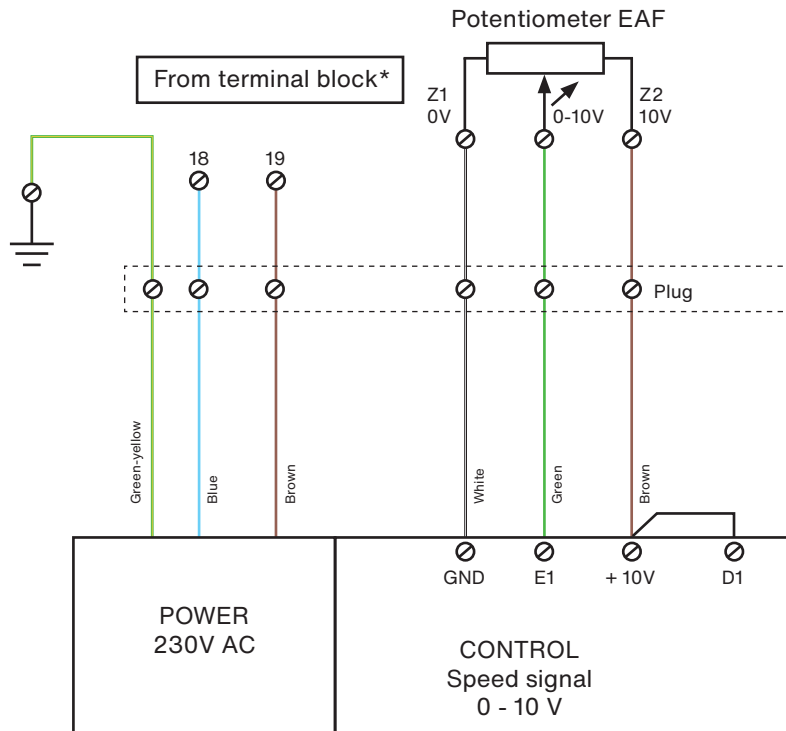

Extract air fan (EAF)

*Power supply terminal block see chapter 18.3 Electrical compartments and user controls.

Zehnder Silvertop 23 motors

Supply

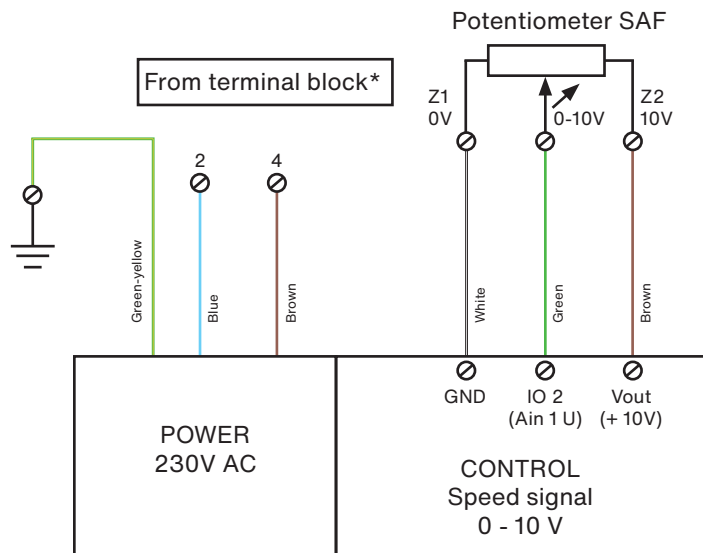

Supply air fan (SAF)

Extract

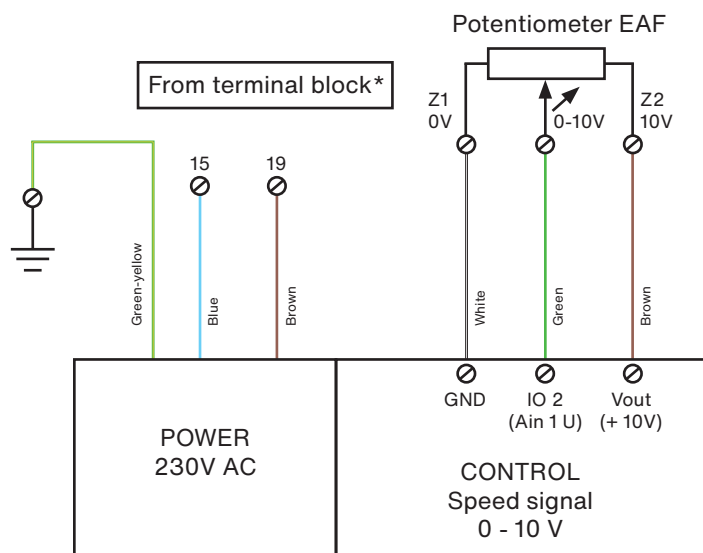

Extract air fan (EAF)

*Power supply terminal block see chapter 18.3 Electrical compartments and user controls.

Zehnder Silvertop 35 motors

Supply

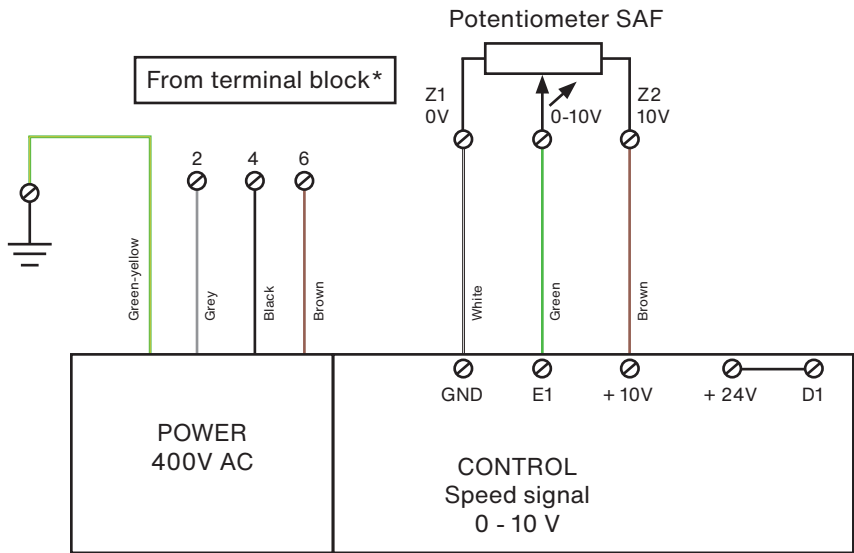

Supply air fan (SAF)

Extract

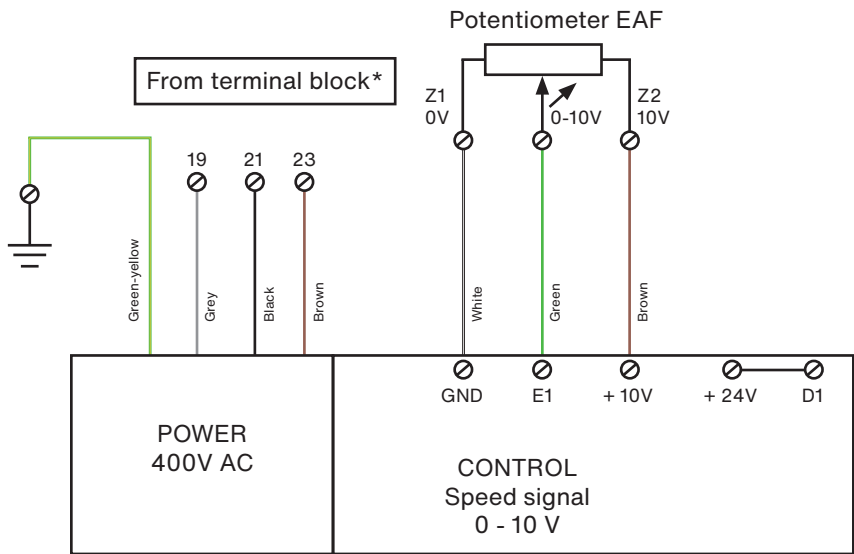

Extract air fan (EAF)

*Power supply terminal block see chapter 18.3 Electrical compartments and user controls.

Zehnder Silvertop 52 motors

Supply

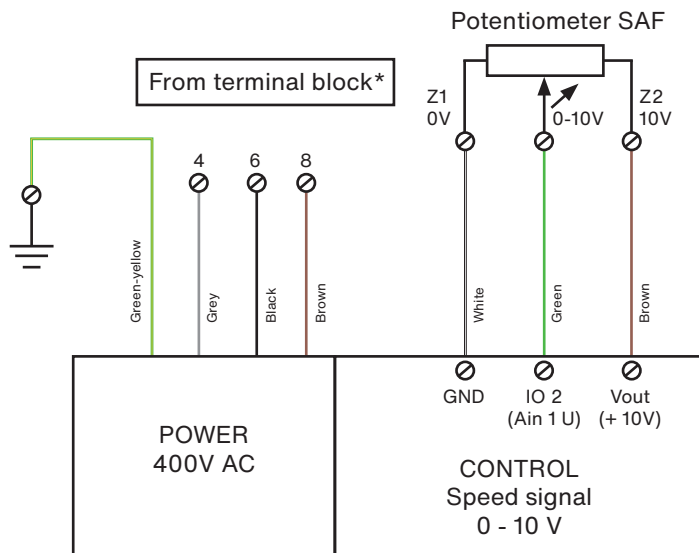

Supply air fan (SAF)

Extract

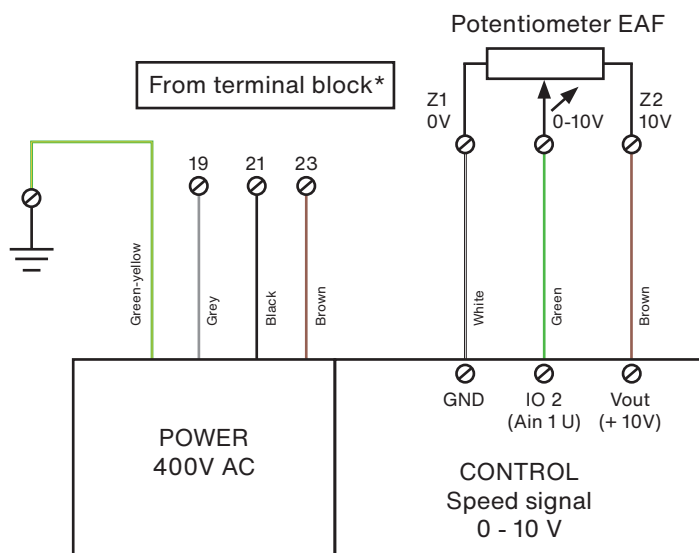

Extract air fan (EAF)

*Power supply terminal block see chapter 18.3 Electrical compartments and user controls.

19. Air performance curves

Zehnder Silvertop 06

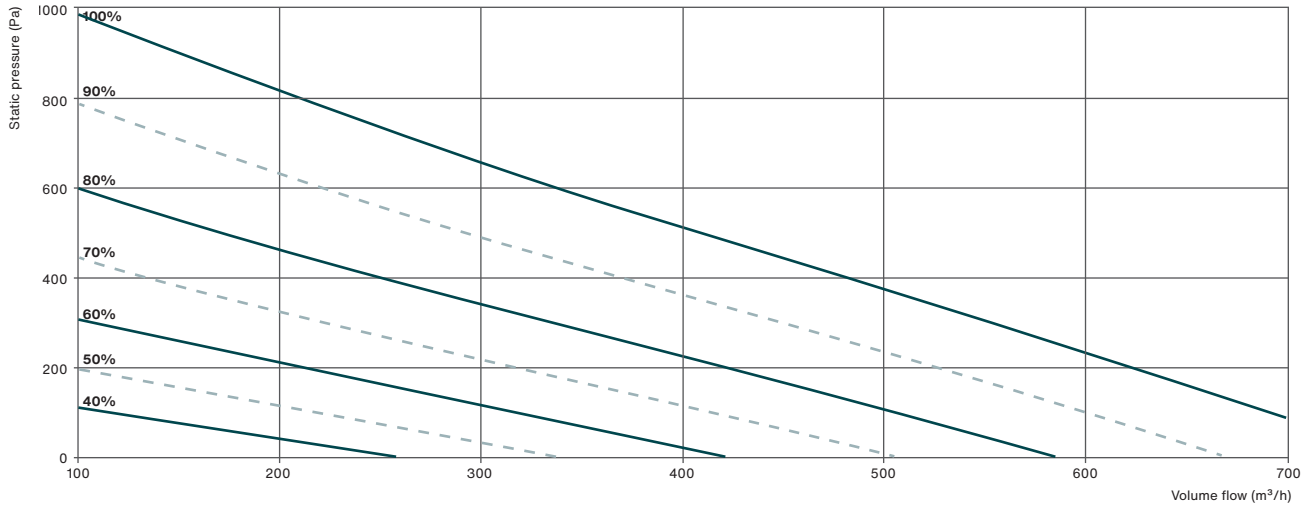

Zehnder Silvertop 08

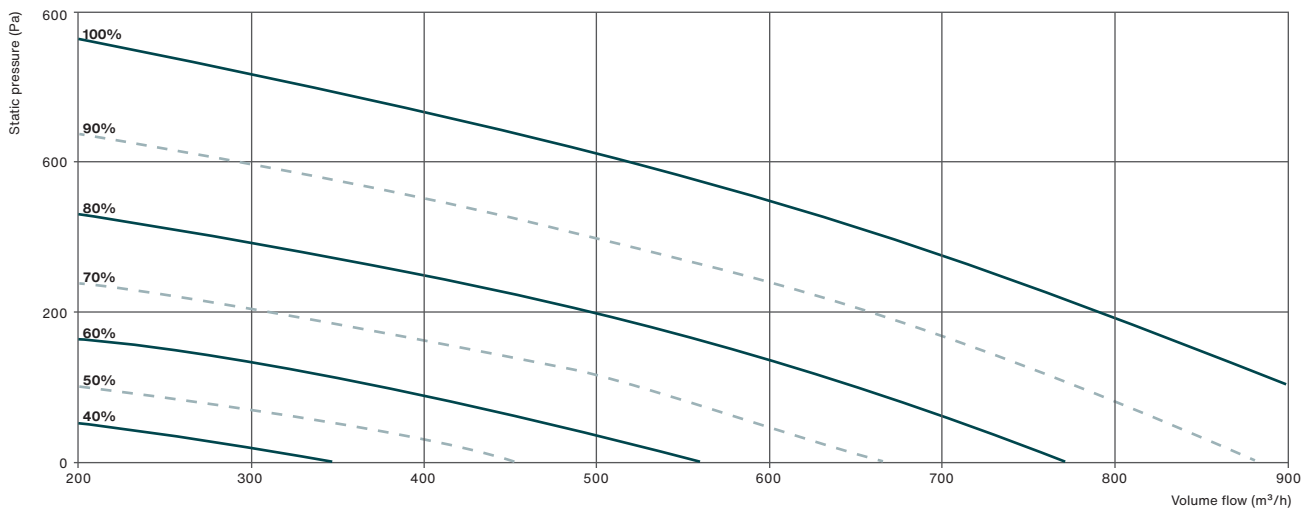

Zehnder Silvertop 15

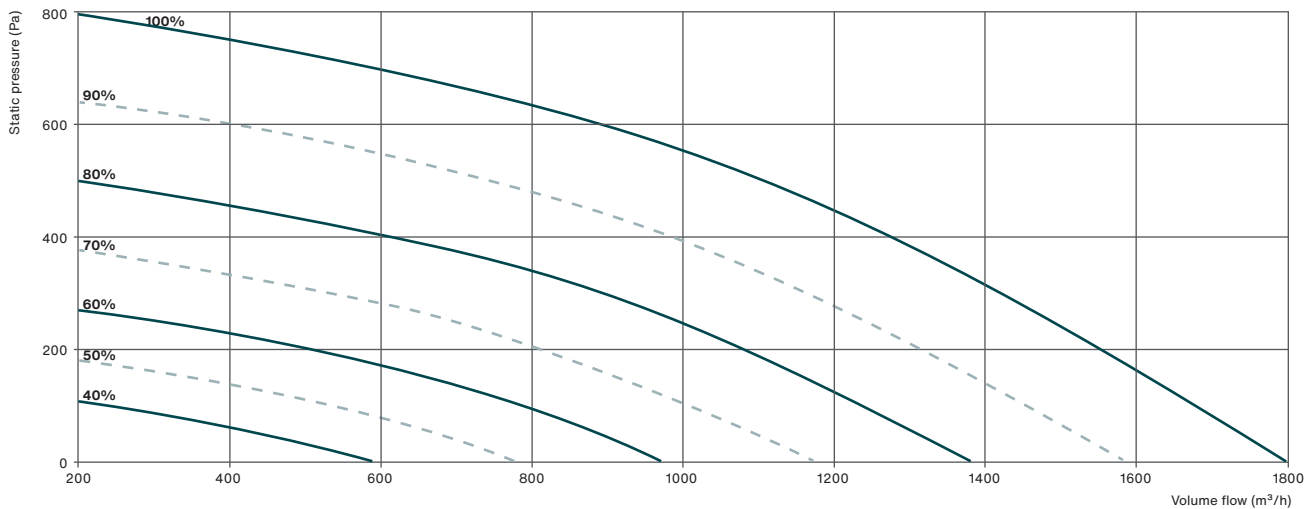

Zehnder Silvertop 23

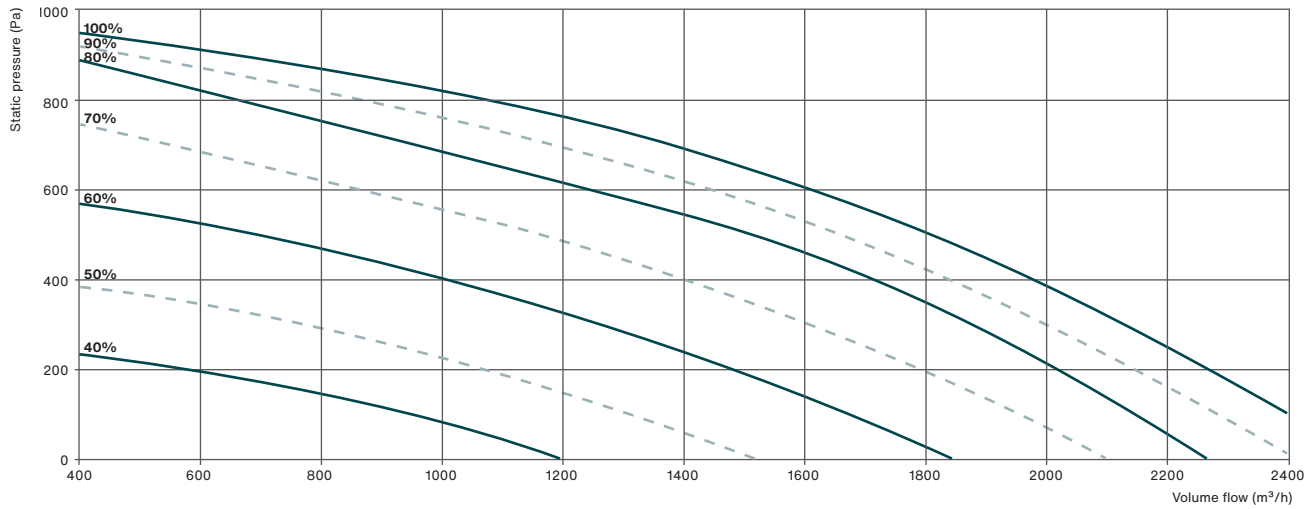

Zehnder Silvertop 35

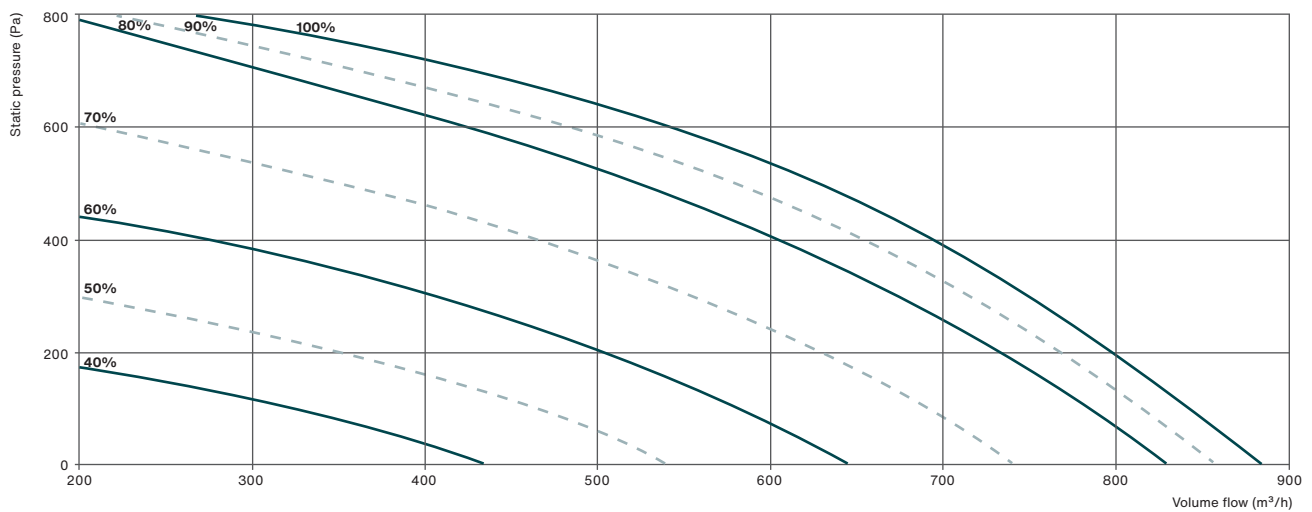

Zehnder Silvertop 52

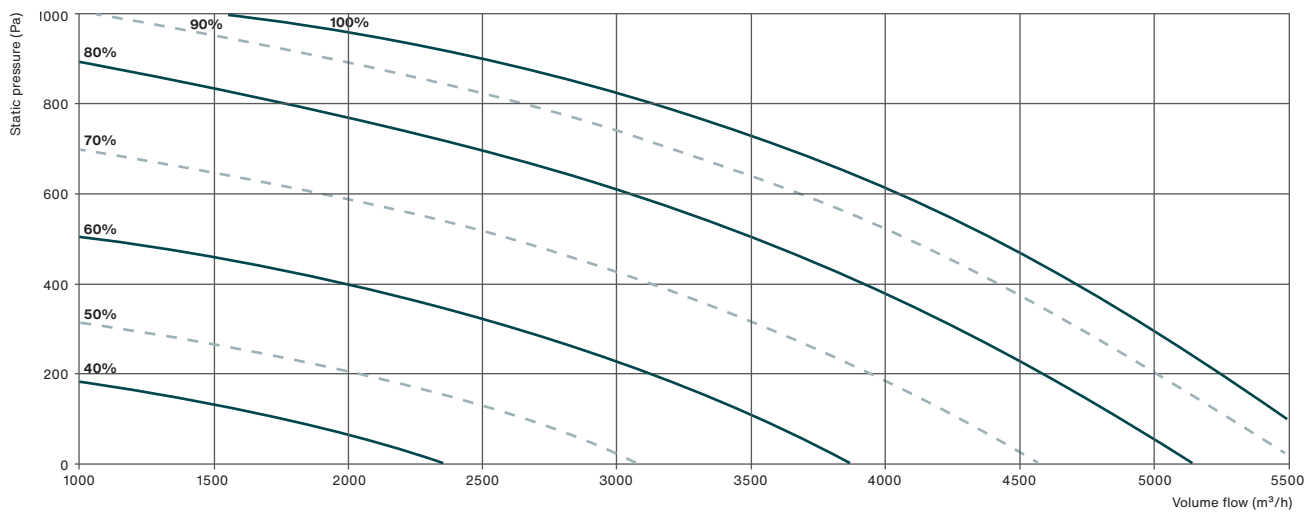

20. Commissioning report

Site			
Address			
Date/...../.....	Technician / company	
Installation	Exterior (roof)		
	Interior (equipment room)		
Material reference			
Manufacturing number			
Version	FIRST / SMART / PREMIUM BE / BREMIUM BC / INFINITE BE / INFINITE BC		
	ECO / LOBBY / MAC2 / DIVA / QUATTRO		
Supply voltage V AC		
Temperature control mode	Constant supply temperature		
	Constant extract temperature		
	Supply air temperature law		
	Extract air temperature law		
Temperature setpoint			
Ventilation setpoints	Supply	Reduced operation: % / Pa / m ³ /h	Reduced operation: % / Pa / m ³ /h
	Extract	Reduced operation: % / Pa / m ³ /h	Reduced operation: % / Pa / m ³ /h
CO₂ setpoints (DIVA / QUATTRO)	Reduced operation: ppm		Reduced operation: ppm

Date	Person involved	Observations

Notes



Notes

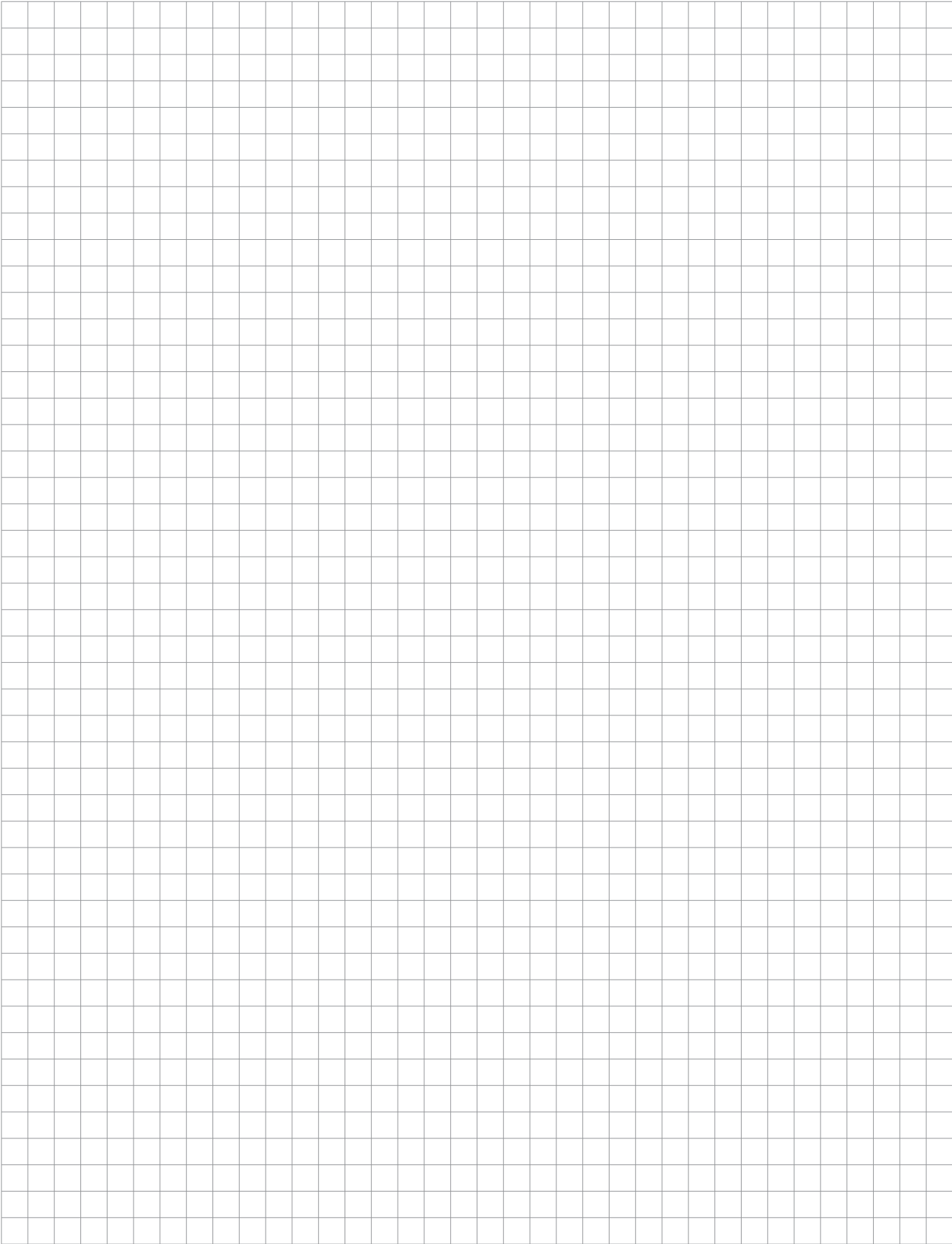

Mâcon Loché, on 29 August 2022

Ref: EU

EU-Declaration of conformity

We declare under our sole responsibility that the products

- ECOVOR™ - ECOBLUE™ - ECONIZER™- NOE™ - NOE LOBBY™
- MINIMAX™ - MINIBLUE™ - MINIBLUE LOBBY™ - MAXIPLUS™ - CITYCOOL™
- COMBIBOX CONCEPT™ - CMH - EVENTYS™
- CARMA™ - NEOTIME™ - FREETIME™ - EXAECO™- HEXAMOTION™- Zehnder Silvertop™ - EVERSKEY™
- ELECTROPACK™ - AQUAPACK™ - LOBBY™ - SYSTEM TOP™ - SYSTEM DIV™ - WONDEROOM™
- CVFMI - CVFTI - CVFM - CVFT
- REFLEX™ - DIABLO™ - PYROSTAR™ - CDF
- EVERKIT™
- THERMOVER™

satisfy the provisions of the following applicable Directives and harmonised standards:

- Machinery Directive 2006/42/EC
- Low Voltage Directive 2014/35/EU
- EMC Directive - Electromagnetic Compatibility Directive 2014/30/EU
- RoHS II Directive - Directives on the restriction of the use of certain hazardous substances in electrical and electronic equipment 2011/65/EU and 2015/863/EU
- ErP Directive 2009/125/EC



Furthermore, for the products

COMBIBOX CONCEPT™ - CMH - CARMA™ - EXAECO™ - EVENTYS™ - FREETIME™ - NEOTIME™ -
HEXAMOTION™ - Zehnder Silvertop™ - THERMOVER™ - EVERKIT™ (Dual flow unit section)

the following standards and specifications were applied:

- EN 1886: 2008 - Ventilation for buildings. Air handling units.
Mechanical performance
- EN 13053+A1: 2011 - Ventilation for buildings. Air handling units.
Rating and performance for units, components and sections.
This declaration is valid only for products installed according to the supplied instructions and
having undergone no modification.

Hervé Nuzzo,
President

CALADAIR INTERNATIONAL

61 Rue Saint-Véran
71000 Macon Loche

Tel.: +33 (0)3 85 36 82 00
Fax: +33 (0)3 85 36 82 01

ZEHNDER CALADAIR INTERNATIONAL ■ 61 Rue Saint-Véran ■ 71000 Mâcon ■ France
T +33 (0)3 85 36 82 00 ■ F+33 (0)3 85 36 82 01 ■ caladair@caladair.com ■ www.caladair.com
S.A.S with capital of EUR 1 000 000 ■ Companies Register Mâcon B317 273 365
SIRET: 317 273 365 00054 ■ VAT No: FR 41 317 273 365 ■ APE 2825Z

