



MECHANICAL VENTILATION WITH HEAT RECOVERY (MVHR)



**NEW
ECO
RANGE**



MECHANICAL VENTILATION WITH HEAT RECOVERY (MVHR - System 4)

ACHIEVES **100%** DUTY IN BYPASS MODE

Mechanical Ventilation with Heat Recovery (MVHR) is fast becoming the most popular strategy for effective whole home ventilation for new build properties.

Solutions for MVHR applications

Nuair offer the widest range of solutions for MVHR applications, including wall and ceiling mounted heat recovery systems. With up to 95% heat efficiencies and 100% duty in Summer bypass, our MVHR range delivers the maximum energy savings.

MVHR How does it work?



NO NEED TO OPEN WINDOWS TO VENTILATE
Clean fresh air is continuously drawn into the property from outside through the intake air ducting.

SAVE ENERGY BY RECOVERING 95% OF HEAT FROM EXTRACT AIR
The MVHR unit takes advantage of the heat in your home. Heat is recovered from the stale extract air, then used to warm the fresh air drawn in from outside. Up to 95% of the otherwise wasted heat is recovered, saving you energy.

BOOST FACILITY
Both the supply and extract air can be boosted at any time by the home owner to increase the ventilation levels.
Light switches, PIRs and Humidistats can be used.

PREVENTS CONDENSATION BY KEEPING MOISTURE LEVELS LOW
Stale air is continuously extracted from the moisture producing areas, such as kitchens and bathrooms.
Intake air is also filtered to remove dust and pollen particles, helping allergy-sufferers.

	MRXBOX-ECO2	MRXBOXAB-ECO2	MRXBOX-ECO3	MRXBOXAB-ECO3	MRXBOXAB-ECO4	MRXBOXAB-ECO-LP2
Page no.	6	6	12	12	18	24
Size (W x H x Dmm)	607x507x356	607x507x356	658x623x432	658x623x432	710x710x585	900x200x700
Weight	20kg	20kg	24kg	24kg	44kg	37kg
Filters	G3	G3	G3	G3	G3	G3
Summer bypass	No	Yes	No	Yes	Yes	Yes
Recognised & listed on PCDB 'Summer bypass'	n/a	Yes	n/a	Yes	Yes	Yes
Maximum floor area (m ²)	150	150	185	185	250	150
Maximum no of wet rooms (SAP 2009)	Kitchen + 7	Kitchen + 7	Kitchen + 7	Kitchen + 7	Kitchen + 7	Kitchen + 6
Specific fan power (SAP 2009 down to)	0.45	0.49	0.44	0.46	0.56	0.54
Heat Recovery % (SAP 2009 up to)	90	90	91	90	94	79
Maximum no of wet rooms (SAP 2012)	Kitchen + 5	Kitchen + 5	Kitchen + 7	Kitchen + 7	Kitchen + 7	Kitchen + 5
Specific fan power (SAP 2012 down to)	0.47	0.52	0.47	0.50	0.62	0.59
Heat Recovery % (SAP 2012 up to)	89	90	91	90	94	79
3rd speed (enhanced airflow)	Yes	Yes	Yes	Yes	Yes	Yes
Spigot size	125mm dia	125mm dia	150mm dia	150mm dia	200mm dia	204mm x 60mm
Opposite handed unit code	MRXBOX-ECO2-OH	MRXBOXAB-ECO2-OH	MRXBOX-ECO3-OH	MRXBOXAB-ECO3-OH	MRXBOXAB-ECO4-OH	MRXBOXAB-ECO-LP2-OH

Ancillaries						
Optional Sensors available	Yes	Yes	Yes	Yes	Yes	Yes
Acoustic Solution - 4-way Silencer	MRXBOX-SIL2	MRXBOX-SIL2	MRXBOX-SIL3	MRXBOX-SIL3	MRXBOX-SIL4	n/a
Acoustic Solution - First Fix Box	MRXBOX-FF2	MRXBOX-FF2	MRXBOX-FF3	MRXBOX-FF3	MRXBOX-FF4	n/a
Acoustic Solution Silencer + First Fix Box	MRX-BOX-SIL2+FF2	MRXBOX-SIL2+FF2	MRX-BOX-SIL3+FF3	MRXBOX-SIL3+FF3	MRXBOX-SIL4+FF4	n/a
Visual System Controller Compatible	Yes	Yes	Yes	Yes	No	Yes

MRXBOXAB-ECO4

and Opposite Handed version

ACHIEVES
100%
DUTY IN BYPASS
MODE

The MRXBOXAB-ECO4 has been designed with automatic 100% bypass as listed on the SAP Product Characteristics Database (PCDB).

Due to its intelligent and smart design, there will be no reduction in airflow when operating in bypass mode resulting in enhanced performance.

The MRXBOXAB-ECO4 is designed to provide optimised balanced (supply and extract) mechanical ventilation with heat recovery and listed on the PCDB.

The unit operates by continuously extracting moisture-laden air from 'wet' rooms within the property and at the same time drawing in fresh supply air from outside. The heat from the extracted stale air is recovered via a heat exchanger inside the heat recovery unit which becomes tempered then filtered before supplying into the habitable rooms creating comfortable and well ventilated homes.

The heat exchanger block within the units can recover up to 95% of the normally wasted heat. The two independent fans have full speed control for background and boost ventilation rates.

The MRXBOXAB-ECO4 has a summer bypass function. This feature activates automatically and attempts to maintain the home at a comfortable temperature. For example, if the outside temperature is warmer than the inside, the unit will continue to draw air through the heat exchanger. If the house is warmer than outside, the unit will bypass the heat exchanger and draw air in directly from outside.



Typical Installation

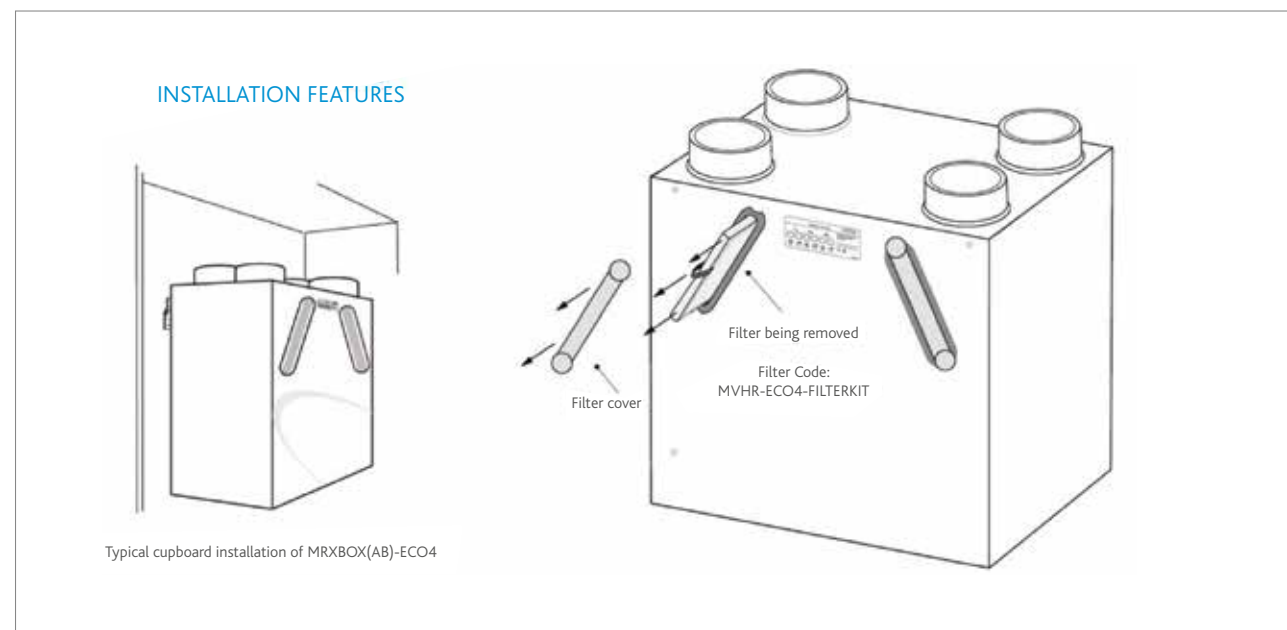

Performance - MRXBOXAB-ECO4

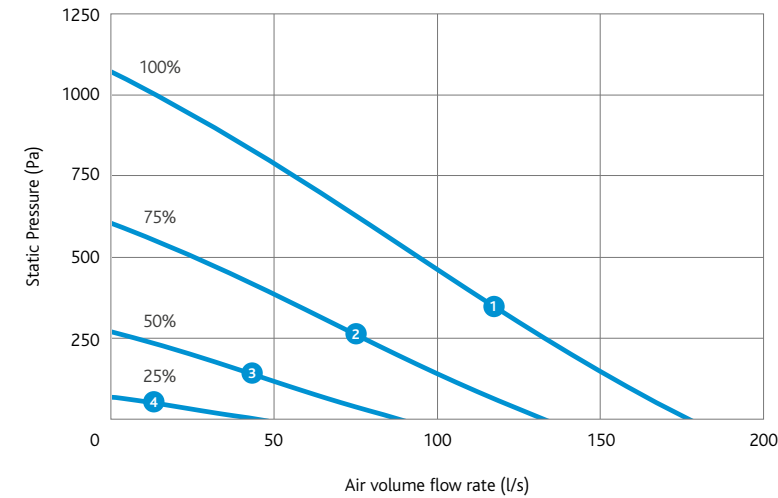

CODE DESCRIPTION

MRXBOXAB-ECO4
Wall mounted unit with 100% bypass and integral humidistat.

MRXBOXAB-ECO4-OH
Opposite handed configuration wall mounted unit with 100% bypass and integral humidistat.

Electrical & Sound

Curve	Maximum power consumption (Watts)		Sound Power Levels dB re 1pW (Frequency Hz)								dBa @3m
			63	125	250	500	1k	2k	4k	8k	
1	350	Open inlet	61	56	56	63	53	48	40	33	
		Open outlet	64	65	66	77	66	64	58	55	
		Breakout	66	63	61	62	49	41	34	26	43
2	152	Open inlet	53	54	54	59	49	43	34	27	
		Open outlet	60	64	62	73	61	58	52	48	
		Breakout	63	61	58	62	47	38	32	22	42
3	41	Open inlet	44	48	45	43	37	33	19	<16	
		Open outlet	51	58	58	55	49	47	38	31	
		Breakout	50	55	54	44	36	29	17	<16	30
4	10	Open inlet	38	34	28	22	18	<16	<16	<16	
		Open outlet	44	42	34	32	25	<16	<16	<16	
		Breakout	39	40	34	22	19	<16	<16	<16	<16

The maximum power consumption shown above (Watts) is consumed on units running continuously, not taking into account any heat recovery saving and based on SAP Product Characteristic Database (PCDB) testing. The breakout case-radiated dBA values are given for Hemispherical free field radiation at 3m - to obtain the Spherical radiated data, subtract 3 dBA.

Please note: Sound data is provided at a particular duty point for 25%, 50%, 75% and 100%. For accurate sound data at a specific speed duty, please use Nuair's fan selector or call the office on 029 2085 8500.

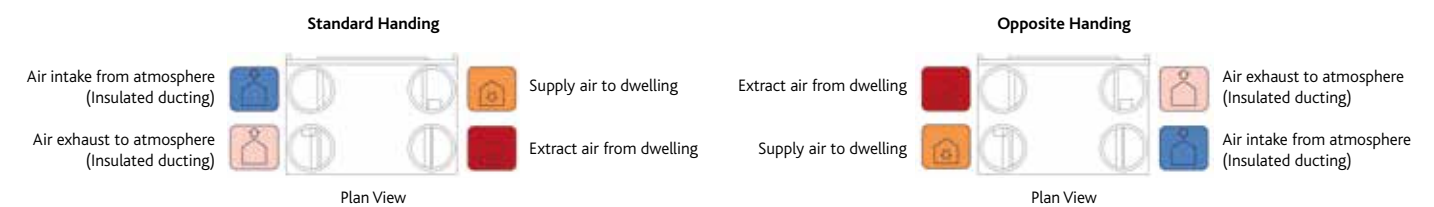

MRXBOXAB-ECO4

SAP 2009 Test Results ▼

Product Code	MRXBOXAB-ECO4		
Application	Specific Fan Power (W/l/s)	Heat Exchange Efficiency	Energy Saving Trust Best Practice Compliant
Kitchen + 1 Wet Room	0.62	94%	Yes
Kitchen + 2 Wet Room	0.56	94%	Yes
Kitchen + 3 Wet Room	0.56	93%	Yes
Kitchen + 4 Wet Room	0.61	93%	Yes
Kitchen + 5 Wet Room	0.67	93%	Yes
Kitchen + 6 Wet Room	0.75	92%	Yes
Kitchen + 7 Wet Room	0.90	91%	Yes

SAP 2012 Test Results ▼

Product Code	MRXBOXAB-ECO4		
Application	Specific Fan Power (W/l/s)	Heat Exchange Efficiency	Energy Saving Trust Best Practice Compliant
Kitchen + 1 Wet Room	0.62	94%	Yes
Kitchen + 2 Wet Room	0.62	93%	Yes
Kitchen + 3 Wet Room	0.66	93%	Yes
Kitchen + 4 Wet Room	0.79	92%	Yes
Kitchen + 5 Wet Room	0.94	91%	Yes
Kitchen + 6 Wet Room	1.15	91%	Yes
Kitchen + 7 Wet Room	1.41	91%	Yes

General Arrangement ▼

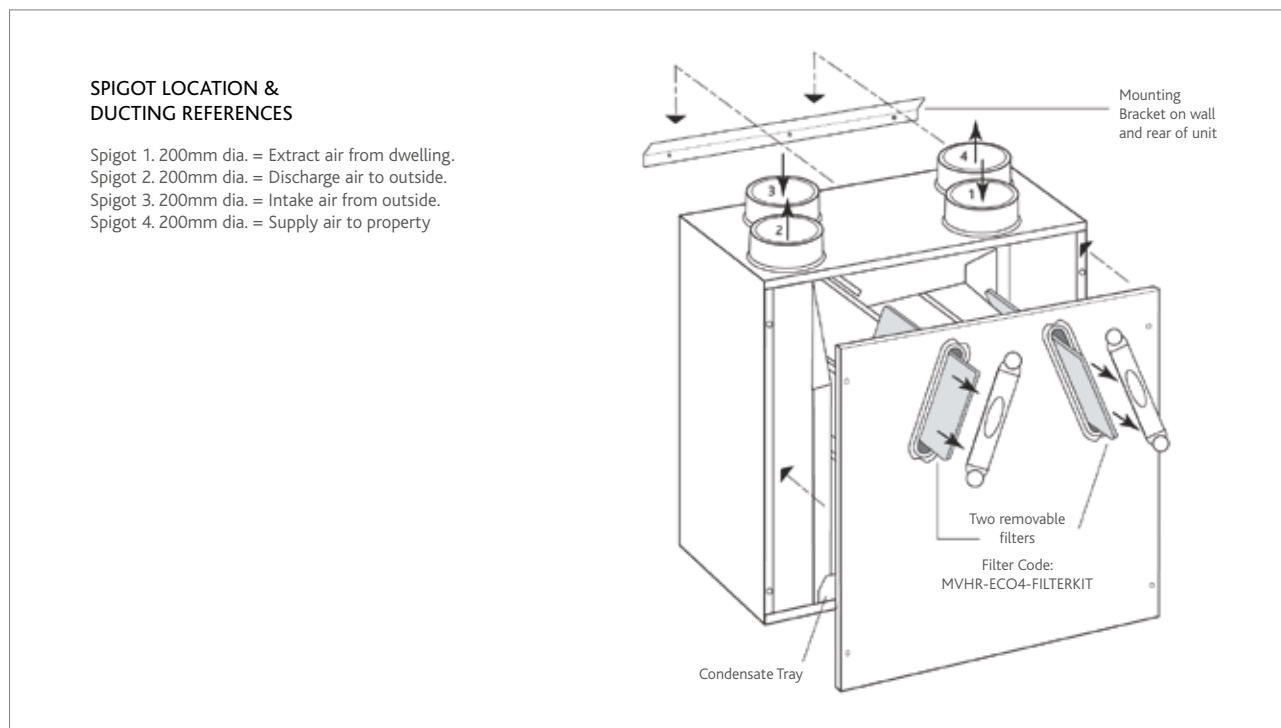

Technical - MRXBOXAB-ECO4 ▼

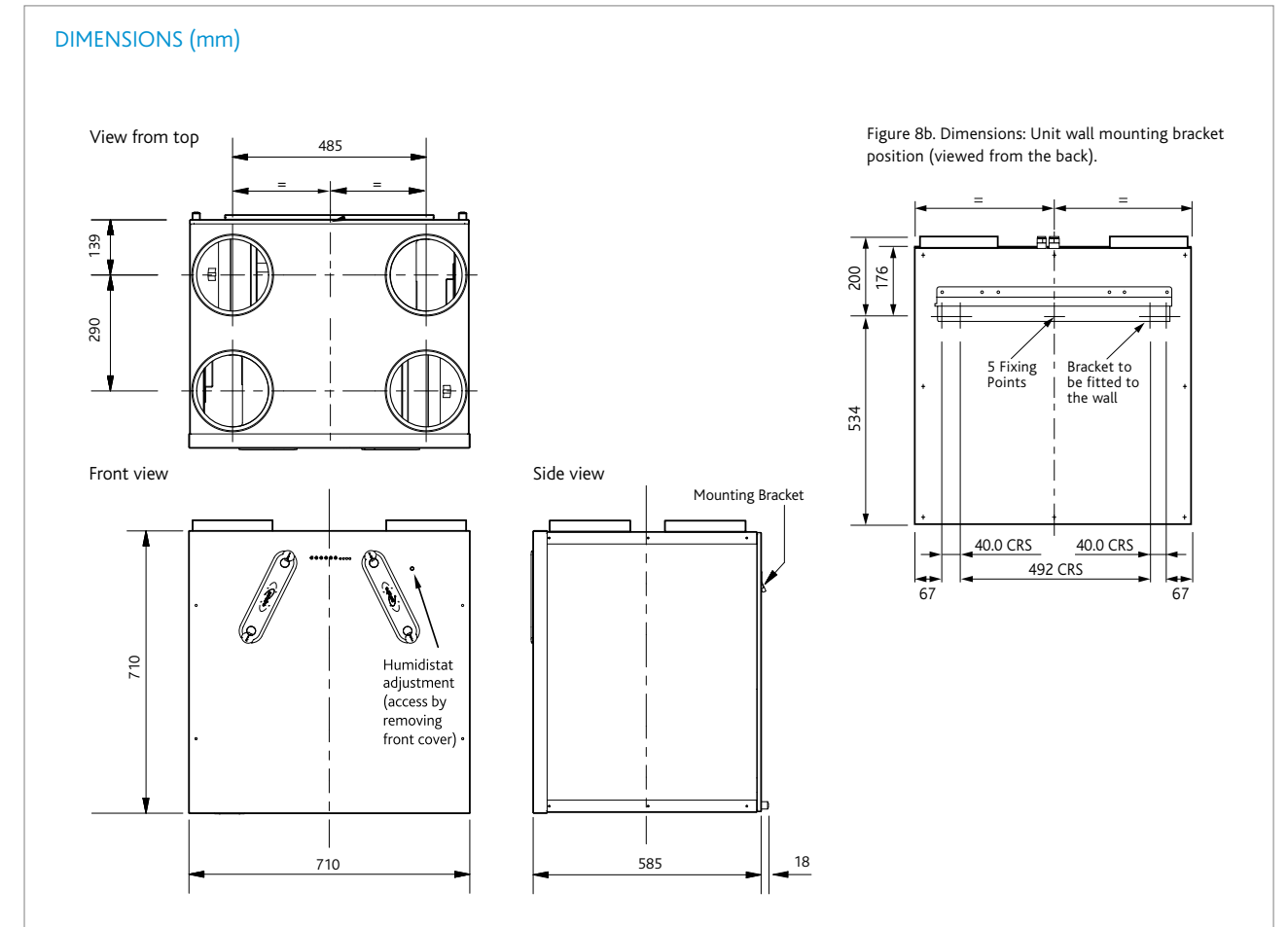

Electrical Details ▼

Please note: The electrical connection of the unit must be carried out by a qualified electrician.

The unit is supplied with a flexible cord for connection to the mains supply.

The mains power supply cable should be connected to a fixed wiring installation in accordance with current IEE wiring regulations.

Electrical Details: MRXBOXAB-ECO4	
Voltage:	230V 1ph 50Hz
Consumption:	2.4 Amp

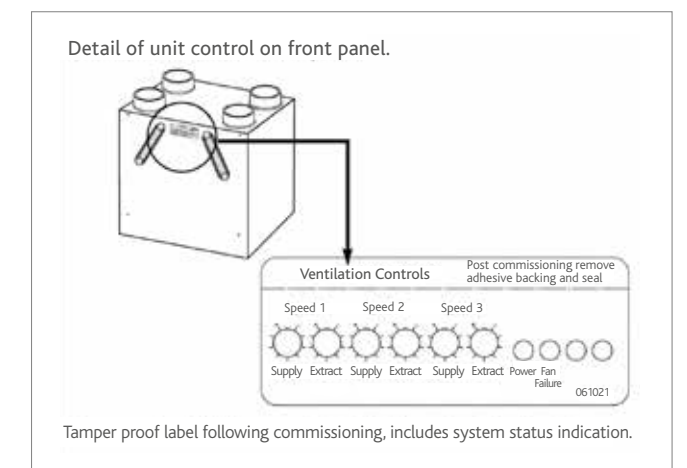

MRXBOXAB-ECO4

Wiring

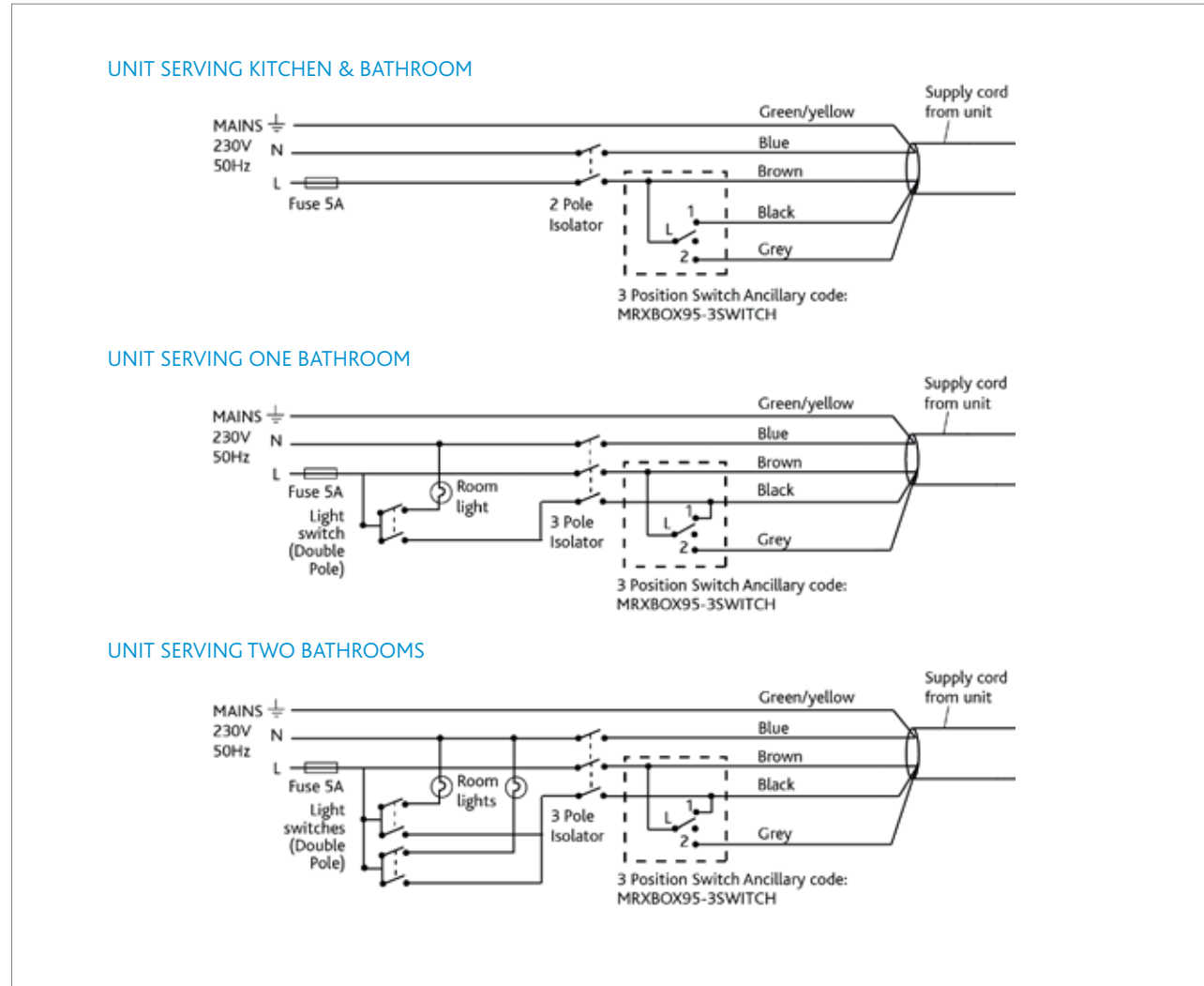

Optional Sensors and Detectors

Customise MRXBOXAB-ECO4 for enhanced performance. All supplied with pre-plugged 10m data cable and incorporates status LED.

MRXBOX95-PIR (Passive Infrared)

A low voltage sensor, detects movement and activates system. Incorporates overrun timer and timer adjustments.

MRXBOX95-HUM (Relative Humidity)

A low voltage sensor, activates the system when the RH level is above set point. Incorporates overrun timer and RH setpoint level adjustment.

MRXBOX95-RFI (Remote Fail Indicator)

If fan failure occurs, the audio visual indicator will flash a warning.



Consultants Specification

SPECIFICATION

The unit shall be fully insulated providing excellent thermal and acoustic characteristics and shall be complete with a multi-plate, counter-flow, high-efficiency heat exchanger block with an efficiency of up to 95%. The heat exchanger shall be protected by G3 grade filters on fresh air inlet and system extract.

The heat exchanger and filters shall be accessible via the front access panel, enabling quick and easy maintenance.

The unit shall have low energy, high-efficiency EC fan/motor assemblies with sealed for life bearings, the impellers shall be backward curved centrifugal type.

The motors shall be suitable for an ambient temperature of 40°C. The unit shall be supplied complete with a condensate drip tray and 32mm drain connection.

The unit shall be suitable for 200mm diameter circular ducting.

Note: The unit is also available in opposite handed format, refer to spigot configuration for set up.

The breakout noise level and power requirements shall be as detailed by the unit manufacturer and in accordance with the ventilation equipment schedule.

The unit shall be MRXBOXAB-ECO4 as manufactured by Nuair and shall be listed on the SAP PCDB.

MRXBOXAB-ECO4-OH is an opposite handed assembly compliant as per standard handed versions listed in SAP PCDB.

OPERATION

The supply and extract ventilation unit shall be positioned as indicated on the drawings and shall be in accordance with the particular fan schedule in the specification.

The combined supply and extract with heat recovery unit shall supply filtered fresh air to each of the habitable rooms and moisture-laden air shall be extracted from the wet areas e.g. bathroom, en-suite, w.c, kitchen, utility rooms, etc. The supply air shall be pre-heated by the warm extract air via the integrated counter-flow heat exchanger element.

The extracted air shall also be filtered before it reaches the heat exchanger block. The ventilation unit shall vary its speed and therefore the ventilation rate, as it receives signals from one of the following:

- Switched live signal from light/remote switches.

When signals are received, the fan shall alter its speed to adjustable, normal and boost rates.

The unit shall have the facility to commission the supply and extract fans independently on minimum speed (continuous background ventilation) and boost speed via inbuilt minimum and maximum speed adjustment. The fans shall have infinitely variable speed control.

INTEGRAL AUTOMATIC HX BYPASS WITH NO REDUCTION IN AIRFLOW

The bypass damper shall open automatically via a wax actuator allowing the air to bypass the heat exchanger to deliver fresh filtered air during the warmer months.

Under normal operation, the automatic bypass diverts 100% airflow around the heat exchanger with no reduction in airflow, as independently tested by the BRE.

INTEGRAL HUMIDITY SENSOR

The integral humidity sensor incorporated within the extract fan chamber will automatically boost both the extract and supply fan, to the commissioned boost speed, when the humidity level exceeds that set by the front panel mounted adjustment potentiometer.

OPTIONAL REMOTE SWITCH (MRXBOX95-3SWITCH)

The unit shall have the facility to wire a three position remote switch to a suitable location within the property. The switch shall have 3 settings: trickle, boost and Summertime boost facility. The remote switch will act as the master switch and will override all other switches.

CONTROL OPTIONS

All versions shall have the following functions integrally mounted within the fan unit on a purpose made PCB, all such components are prewired and factory fitted by the manufacturer:

- Independent control of background supply and extract flow rates.
- Independent control of boost speed supply and extract flow rates.
- Integral fan failure indication.
- Integral S/L terminal for boost to commissioned level, from remote switch, e.g. light switch.
- Integral S/L terminal for third speed (purge), boost speed, from remote switch e.g. plate switch.
- Integral heat exchanger frost protection.
- Discreet daily run monitor.
- Indication and controls - The unit shall have clear LED visual indication for maintenance, servicing and operation mode i.e. HX bypass, frost protection.

The unit shall be offered with a 5 year warranty which starts from the day of delivery, and includes parts and labour for the first year and parts only for the remaining 4 years.