

Installer contact details:

Company name:
Contact name:
Tel:
Email:

Notes :

# HRX2D

With Bluebrain controller

**Mechanical Ventilation with Heat Recovery appliance**

### Installation and Operating Instructions

**Model: HRX2D**

**These instructions must be given to the householder**

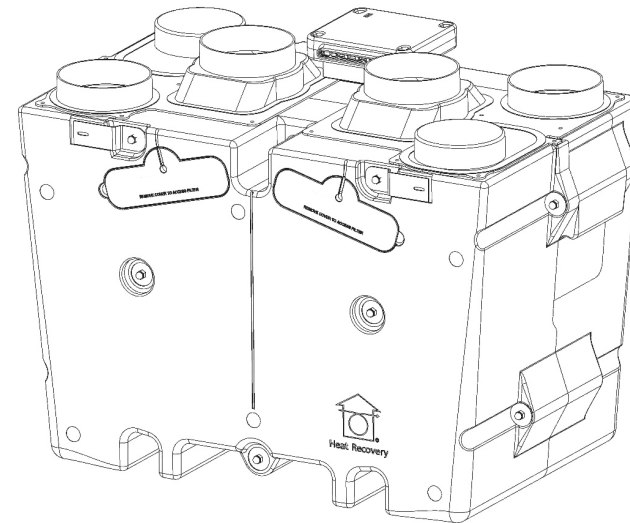

**DO NOT SWITCH OFF THE UNIT – it is designed to run continuously. If the unit is switched off, indoor pollutants and moisture levels may increase which could endanger your health or damage your home.**

**It is important to follow the advice in this manual and correctly maintain the system to ensure a healthy indoor environment.**

## Warnings & Safety Information

### **IMPORTANT! PLEASE READ THESE INSTRUCTIONS CAREFULLY BEFORE COMMENCING INSTALLATION**

1. Do not install this appliance in areas where the following may be present or occur:
  - Pollution degree 3 or 4 (as defined in EN 60335-1)
  - Excessive oil or a grease laden atmosphere
  - Corrosive or flammable gases, liquids or vapours
  - Be subject to direct water spray
  - Ambient temperatures higher than 50°C and lower than -25°C
  - Possible obstructions that may hinder access or removal of the unit
2. This fan can be used by children aged from 8 years and above and persons with reduced physical, sensory or mental capabilities or lack of experience and knowledge if they have been given supervision or instruction concerning use of the appliance in a safe way and understand the hazards involved. Children shall not play with the appliance. Cleaning and user maintenance shall not be made by children without supervision.
3. All wiring must be in accordance with the current IEE Wiring Regulations BS7671. The electrical installation should be inspected and tested by a suitably qualified person after completion.
4. The appliance should be provided with a local double pole fused spur fitted with a 3Amp fuse and a minimum contact separation of at least 3mm.
5. Ensure that the mains supply (Voltage and Frequency) complies with the rating label.
6. This appliance must be earthed.
7. When installing the appliance, care should be taken not to damage any hidden utilities.
8. The installer is responsible for the installation and electrical connection of the HRX2D system on site. It is the responsibility of the installer to ensure that the equipment is safely and securely installed and left only when electrically and mechanically safe.
9. All regulations and requirements must be strictly followed to prevent hazards to life and property, both during and after installation and any subsequent servicing or maintenance.

### **All models are IPX2 rated**

#### **The HRX2D unit is free from the following substances:**

- **Asbestos**
- **Oils containing polychlorinated biphenyl**
- **Aluminum wires**
- **Components containing mercury**
- **Wood, cotton, silk, ordinary paper, hygroscopic material etc is not used, unless impregnated**

10. In dwellings where it is intended to install open-flue appliances and extract ventilation, the combustion appliance should be able to operate safely, whether or not the fans are running. A way of showing compliance with The Building Regulations in these circumstances would be to follow the installation guidance shown below, and to show by tests that combustion appliances operate safely, whether or not the fans are running.

- A. For gas appliances: where a room contains an open-flue appliance, the extract rate should not exceed 20l/s (72m<sup>3</sup>/h).
- B. For oil appliances: where a room contains an open-flue appliance, the extract rate should be limited to 40l/s (144m<sup>3</sup>/h) for an appliance with a pressure jet burner and 20l/s (72m<sup>3</sup>/h) for an appliance with a vaporising burner.
- C. For solid fuel appliances: avoid installing extract ventilation in the same room.

Further reference should be made to Approved Document J of the Building Regulations.

11. A condensate drain should be installed from the appliance to an appropriate drain location. Domus recommend the Domus 297 dry- trap and condensate drain kit.

12. The condensate drain and associated pipe work must be cleared of debris prior to commissioning and insulated where it passes through unheated spaces and voids.

13. This appliance should not be connected to a tumble dryer or cooker hood.

14. The supply air must be drawn from the exterior of the property.

15. The extract air must be expelled to the exterior of the property.

16. It is recommended that the two external terminals or grilles are set at least 2m apart.

17. The supply and exhaust ceiling valves should be positioned at least 300mm from internal walls to allow airflow measuring equipment to fit correctly over the valves.

18. All ducting should be insulated with Domus Thermal duct insulation where it passes through unheated spaces and voids (e.g. loft spaces) to reduce the possibility of condensation forming and heat loss. Additionally, both ducts connecting the HRX2D to outside must be insulated to avoid condensation forming on the outside of the ducts.

## Contents

<b>1.1 Overview</b>	<b>Page 6</b>
<b>1.2 Physical specification</b>	<b>Page 8</b>
<b>1.3 Main features</b>	<b>Page 8</b>
<b>1.3.1 Thermal bypass</b>	<b>Page 8</b>
<b>1.3.2 Frost protection</b>	<b>Page 9</b>
<b>2.0 Installation</b>	<b>Page 9</b>
<b>2.1 Overview</b>	<b>Page 9</b>
<b>2.2 Preparation</b>	<b>Page 9</b>
<b>2.3 Fitting the condensate drain kit</b>	<b>Page 10</b>
<b>2.4 Ducting guidelines</b>	<b>Page 11</b>
<b>3.0 Electrical</b>	<b>Page 12</b>
<b>3.1 Overview</b>	<b>Page 12</b>
<b>4.0 Commissioning</b>	<b>Page 14</b>
<b>4.1 Overview</b>	<b>Page 14</b>
<b>4.2 System balancing</b>	<b>Page 14</b>
<b>5.0 User control interface (Bluebrain) operation</b>	<b>Page 15</b>
<b>5.1 Time and date setting</b>	<b>Page 16</b>
<b>5.2 Pre-commissioning</b>	<b>Page 17</b>
<b>5.3 Commissioning</b>	<b>Page 17</b>
<b>5.4 Automatic thermal bypass activation/inactivation</b>	<b>Page 18</b>
<b>5.5 Automatic humidity controlled boost activation/inactivation</b>	<b>Page 19</b>
<b>5.6 Filter reminder adjustment/inactivation</b>	<b>Page 19</b>
<b>5.7 Frost protection trigger temperature adjustment</b>	<b>Page 19</b>
<b>5.8 Delay-on timer activation/deactivation</b>	<b>Page 20</b>
<b>5.9 Delay-off timer activation/deactivation</b>	<b>Page 20</b>
<b>5.10 Setting the automatic summer bypass operating temperature</b>	<b>Page 21</b>
<b>5.11 Setting the optional duct-heater operating temperature (°C)</b>	<b>Page 21</b>
<b>5.12 Setting the humidity activated boost switching level (% RH)</b>	<b>Page 22</b>
<b>5.13 Programming</b>	<b>Page 22</b>
<b>5.14 Filter check reminder</b>	<b>Page 23</b>
<b>5.15 Default interface factory settings</b>	<b>Page 24</b>
<b>6.0 Maintenance</b>	<b>Page 26</b>
<b>6.1 Routine maintenance</b>	<b>Page 26</b>

## 8.0 Warranty

### LIMITED TWO YEAR WARRANTY

In the event that any problem or fault develops with the product due to faulty materials or workmanship during the two year period beginning on the date on which you purchased the product then subject to the various limitations and exclusions as detailed below, Domus will as soon as reasonably possible either repair or replace the product during its usual working hours or, at Domus' discretion, provide you with a refund of the purchase price which you paid for the product.

If you need to make a claim under this warranty, then please contact Domus using one of the following methods:

Tel: +44 (0)3443 715523

Website: [www.domusventilation.co.uk](http://www.domusventilation.co.uk)

The above warranty does not apply to nor cover the repair of any problem or fault with the product which arises as a result of: (a) failure to install, operate, maintain and/or repair the product or any associated parts and components (including any ducting) using reasonable skill and care and in accordance with the instructions provided with it (unless the original installation, maintenance or repair which gave rise to the problem or fault was carried out by or on the behalf of Domus in which case this exclusion will not apply); (b) use of the product for any purposes other than those for which it is designed; (c) modifications made to the product by anyone other than Domus or its approved contractors; (d) deliberate damage; and/or (e) damage caused by fire, flood or other water damage, explosions, rust or corrosion.

Domus may carry out the repair or replacement of the product itself or using an approved sub-contractor but will always remain liable to you for the acts or omissions of any such sub-contractor as if those were the acts or omissions of Domus itself.

Where you have purchased the product acting in your capacity as a consumer then the above warranty is offered by Domus in addition to and is not intended to affect or lessen those statutory rights which you became entitled to as a consumer when you purchased the product. In the UK you can find out more about your rights as a consumer by visiting the website of the Citizen's Advice Bureau ([http://www.adviceguide.org.uk/england/consumer\\_e.htm](http://www.adviceguide.org.uk/england/consumer_e.htm)).

'Fail (fan 1)' displayed on the controller LCD screen	<ul style="list-style-type: none"> <li>• Check the electrical connections for fan 1 on the main PCB. There are four connections at the top of the board for control and three at the bottom of the board for power</li> <li>• By removing the exhaust duct connection, check there is nothing obstructing fan 1</li> </ul>
'Fail (fan 2)' displayed on the controller LCD screen	<ul style="list-style-type: none"> <li>• Check the electrical connections for fan 2 on the main PCB. There are four connections at the top of the board for control and three at the bottom of the board for power</li> <li>• By removing the supply duct connection, check there is nothing obstructing fan 2</li> </ul>
Little or no air is extracting or supplying through the room valves	<ul style="list-style-type: none"> <li>• Check that the filters have been removed from the pre-commissioning protective covers</li> <li>• Check that the filters are not blocked</li> <li>• Check that the system has been commissioned correctly</li> <li>• By removing the exhaust and supply duct connections check there is nothing obstructing the fans</li> </ul>
The unit is excessively noisy	<ul style="list-style-type: none"> <li>• Check that the system has been commissioned correctly</li> <li>• By removing the exhaust and supply duct connections check there is nothing obstructing the fans</li> </ul>

7.2 If the fault/faults cannot be resolved using the table in section 7.1, contact the Domus Ventilation Customers Services team on 03443 715523.

## 7.0 Faults

- 7.1 Fault finding
- 7.2 Contact details

## 8.0 Warranty

Page 26

Page 26  
Page 26

Page 28

## 1.1 Overview

- 1.1.1 The **Domus HRX2D** appliance is a key part of a whole house ventilation system specifically designed to improve indoor air quality in dwellings. The system is designed to provide measured amounts of filtered, fresh air to living areas while constantly removing polluted, stale air from bathing, cooking and washing areas at the same gentle rate. Any available heat in the outgoing stale air is recovered by a built-in heat exchanger and used to pre-warm the fresh supply air
- 1.1.2 A programmable user interface is provided to thereby maintaining a comfortable indoor environment and includes the following features:
- Time and date functions
  - Independent fan control adjustable at three levels; Low, Boost, Max
  - Programmable filter check reminder
  - Programmable 100% Thermal bypass
  - Optional 3 minute delay-on boost switching
  - Optional 5 to 30 minute delay-off boost switching
  - Optional programmable frost protection
  - Programmable humidity level boost switching
  - Temperature controlled switching available for optional duct heater (supplied by others)
  - Elapsed runtime meter
- 1.1.3 The boost facility can also be triggered from a lighting circuit; contacts to accommodate external sensors or switches are also available (see page 10)
- 1.1.4 The G3 filters in the appliance ensure that the fresh supply air is clean as it enters the home. Additionally, the stale extract air is filtered to protect the heat exchanger from unwanted contamination. **These filters have to be cleaned regularly**, depending on the levels of pollution. The filters should be replaced when they start to show visible signs of wear
- 1.1.5 This product is listed in the NCM PCDB, (was SAP Appendix Q) therefore, part of the installation process requires that an installation checklist is completed and submitted to the Building Control Body (BCB). Blank checklists are available at [http://www.ncm-pcdb.org.uk/sap/filelibrary/pdf/Check\\_Lists/Domestic\\_Ventilation\\_Compliance\\_Guide\\_2010\\_-\\_Checklist\\_\(extract\).pdf](http://www.ncm-pcdb.org.uk/sap/filelibrary/pdf/Check_Lists/Domestic_Ventilation_Compliance_Guide_2010_-_Checklist_(extract).pdf)
- 1.1.6 Pack includes:
- Domus HRX2D appliance
  - User control interface (Bluebrain controller)
  - 4m length of 4 core signal cable (to connect HRX2D wiring centre and user-control)
  - Installation and operating instructions manual
  - Householders operating manual
  - ErP label and data fiche
- 1.1.7 Ancillary items as required:
- Domus 220x90mm rectangular rigid duct system or,
  - Domus Ø150mm rigid duct system or,
  - Domus Radial duct system
  - Domus Thermal duct insulation
  - Domus 297 dry-trap and condensate drainage kit

## 6.0 Maintenance

### 6.1 Routine maintenance

- 6.1.1 The two appliance G3 filters should be cleaned on a regular basis, the exact frequency will be determined by individual living conditions.
- 6.1.2 The word 'FILTER' will appear on the home screen of the digital user-interface after the set time has elapsed – when this occurs, clean the filters – see 5.1.4 for resetting details.
- 6.1.3 Before cleaning the filters, turn off the appliance at the isolator switch.
- 6.1.4 To remove the two filters, pull out the two caps from the front of the appliance and gently slide out the filters in their carrier frames.
- 6.1.5 Lightly vacuum the filters to remove surface debris and then gently wash through in warm soapy water. Ensure that the filters are completely dry before refitting. **Important:** do not dry on a radiator or use excessive heat as this may distort the carrier frames.

## 7.0 Faults

### 7.1 Fault finding

**Caution - the electrical supply to the unit and from any external triggers into the unit must be isolated before removing covers to electrical connections.**

Fault	Checks and possible solutions
Nothing displayed on the controller LCD screen	<ul style="list-style-type: none"> <li>• Check there is power connected to the unit. Presence of an orange light visible from outside the white wiring centre box will indicate this.</li> <li>• Check the electrical connections between VCC (on controller) and 5V (on PCB)</li> <li>• Check the electrical connections between GND (on controller) and GND (on PCB)</li> </ul>
'Unconnect' displayed on the controller LCD screen	<ul style="list-style-type: none"> <li>• Check the electrical connections between TD (on controller) and RXD (on PCB)</li> <li>• Check the electrical connections between RX (on controller) and TXD (on PCB)</li> </ul>
'Fail' displayed on the controller LCD screen	<ul style="list-style-type: none"> <li>• If relevant, check with the building management services team if the external inhibit function has been activated</li> <li>• If connected, check the smoke detector isn't activating the external inhibit function</li> <li>• If no external inhibit control is connected, check there is a link wire present between the two terminals of the external inhibit connection on the main PCB</li> <li>• Check the electrical connections of the aforementioned link wire between the two terminals of the external inhibit on the main PCB</li> </ul>

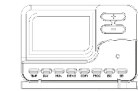
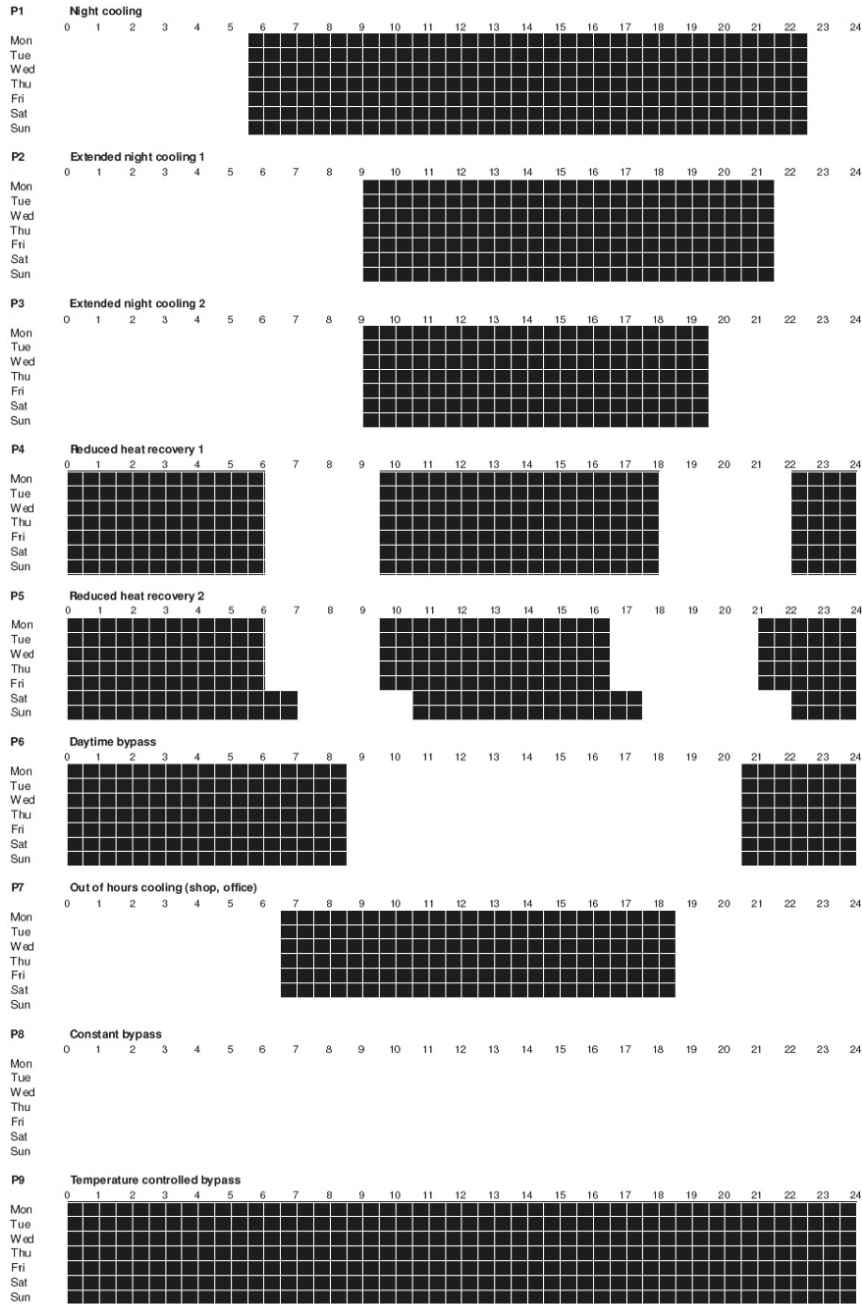

USER CONTROL  
INTERFACE  
(Bluebrain controller)

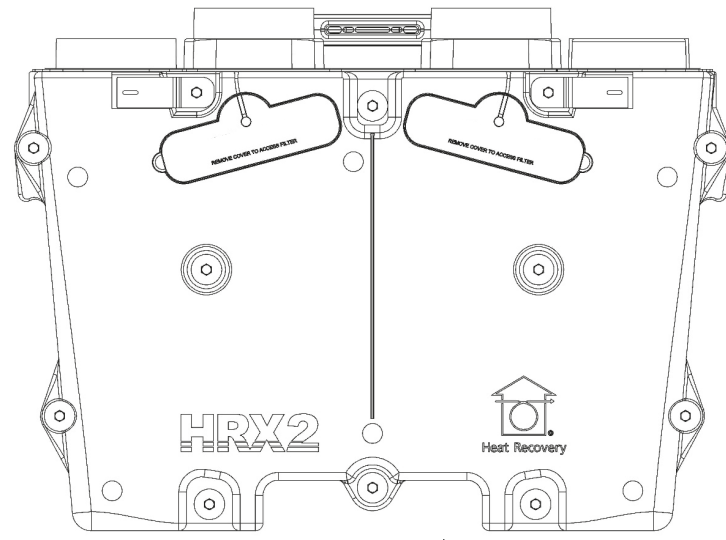

DOMUS HRX2D  
MVHR UNIT

**1.2 Physical specification**

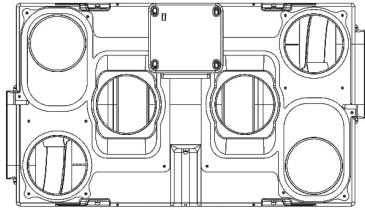
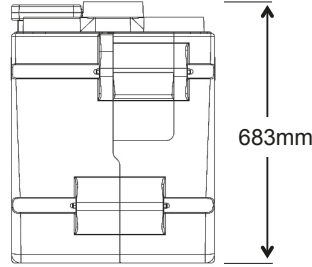
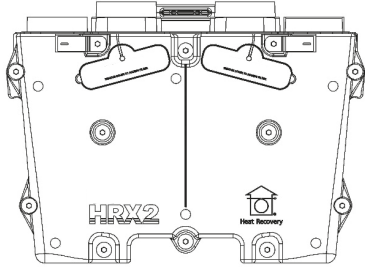

**1.3 Main features**

**1.3.1 Thermal bypass**

1.3.1.1 The HRX2D model is fitted with a fully automatic heat exchanger bypass mechanism. Time clock control and manual override are also available

1.3.1.2 In automatic mode, the bypass will open when the indoor target temperature reaches a pre-set value. Using the interface, the trigger temperature can be set between +15°C and 25°C

1.3.1.3 The interface contains an optional frost protection system. During periods of very cold weather, the fresh air supply fan will automatically reduce in speed to approximately 20% of its commissioned setting to reduce the load on your heating system and avoid possible freezing of the heat exchanger. During these periods, the extract fan will increase in speed to its commissioned boost speed to maintain an even air pressure. Using the interface, the trigger temperature can be set between -15°C and +5°C

**5.15 Default interface factory settings**

P1

t3 - 20°C

t4 - 10°C

Humidity – 60%

Filter – 3000 hours

Fan 1 – Low 20%

Fan 1 – Boost 50%

Fan 1 – Max 80%

Fan 2 – Low 20%

Fan 2 – Boost 50%

Fan 2 – Max 80%

Bypass temp – off

T5

Delay-on – off

Delay-off – off

Hum - on



Press the “+” and “-” buttons to move along the timeline at the bottom of the screen; a block will be **added** to each position.

To remove a block, remove the word “**BYPASS**” from the screen by pressing “**BYPASS**” and press the “+” and “-” buttons to move along the timeline at the bottom of the screen; a block will be **removed** from each position.

Daily ‘timeline patterns’ can be **copied** to another day or multiple days to avoid programming each day individually.

From the home screen, press “**COPY**”

Select the day to copy by pressing “**PROG**” (the day number will be displayed) and then the day to copy-to by pressing the “+” and “-” buttons (the day number will flash). When the two correct days have been selected, press “**COPY**” and the timeline pattern will copy across.

Press “**SET**” to record

#### 5.14 Filter reminder

The word ‘Filter’ will appear on the home screen after the set time has elapsed. When this occurs, clean the filters (see section 6)

Note: The figure at the bottom of the screen indicates elapsed operating time in hours. When the numbers are **not** flashing, they indicate the elapsed time since the last filter reset. If “**DAY**” is pressed, the numbers will flash and indicate the total elapsed operating time in hours.

To reset the filter elapsed time reminder following cleaning, press and hold “**SET**” for 5 seconds.

## 2.0 Installation

### 2.1 Overview

2.1.1 The following instructions are intended to help prevent hazards. Installation should only be carried out by a qualified electrician and competent persons in clean, dry conditions where dust and humidity are at minimum levels

Note: we advise installers to fix all mains, switch and sensor wiring (in accordance with the latest edition of the Wiring Regulations) prior to fixing the HRX2D unit in position

### 2.2 Preparation

- 2.2.1 When accepting delivery of the appliance, inspect for transit damage. If in doubt, call our Customer Services team on 03443 715523
- 2.2.2 The HRX2D unit must be fitted horizontally in a portrait orientation to a vertical and solid flat surface using the fixing bracket provided
- 2.2.3 Appropriate screw fixings to suit the support medium will need to be supplied by the installer. The built-in mounts suit 4 x 4mm (No.8) pan head screws
- 2.2.4 **Important:** Ensure that there is sufficient space for access to the wiring centre (cover removal), the condensation fittings and ductwork
- 2.2.5 Ensure that there is sufficient space below the appliance to access the filters and for carrying out any future maintenance on the appliance
- 2.2.6 To wall mount the unit, firstly decide on the correct handing (left or right) based on the most convenient duct routing to inside and outside the property. Once established, lift up the 2 folded away mounting brackets which will be at the back of the unit into an upright position. Drill 2 holes at 460mm centres and level with each other onto the surface to which the unit will be mounted. Using suitable fixings, securely attach the unit to the wall.

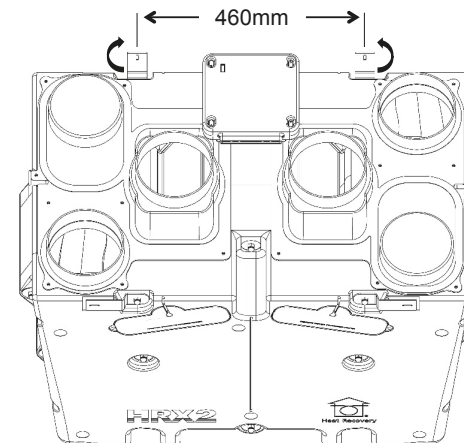

2.2.7 The unit can be installed onto a solid base without the need to mechanically fix it down. A platform may need to be built up below the unit to ensure space for fitting a condensate drain and allowing substantial fall in the pipework.

2.2.8 When viewed from the front, the filter access and duct configuration is as shown on the diagram below:

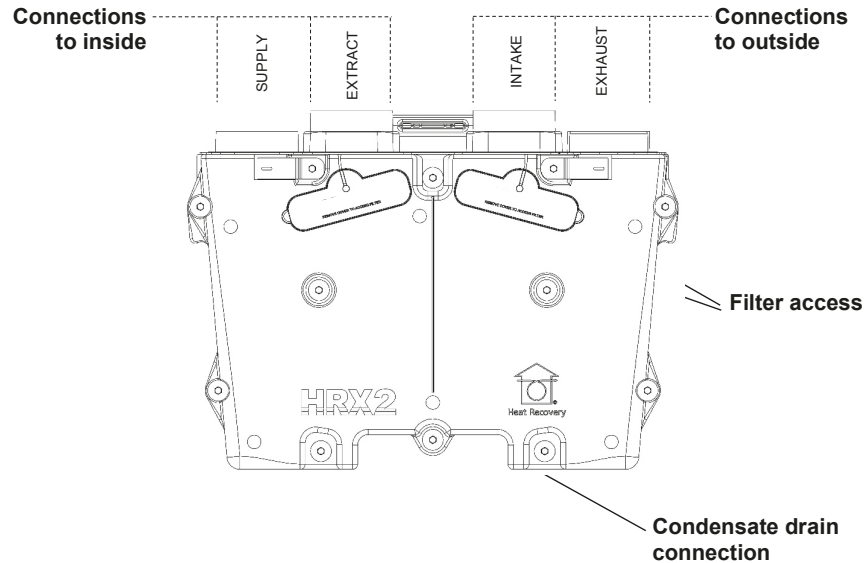

5.12 Setting the humidity activated boost switching level (%RH) (for activation see 5.5)

From the home screen, press "**HUM**" to move to the humidity (% RH) activated boost setting (Factory default 60% RH – recommended)

Use the "+" or "-" buttons to set the humidity switching level in steps of 1% RH (range 30-85%RH)

Press "**SET**" to record or "**ESC**" to discard the settings and return to the home screen

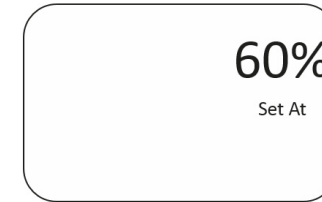

5.13 Programming

From the home screen, press "**PROG**" (The programme number will flash in the bottom left hand corner; P1 to P9)

Use the "+" and "-" buttons to view the selected programme number (Factory default is P9)

The pre-programmed Thermal bypass programmes are shown in the diagram on page 18

Note: Each square has a time value of 30 minutes. Black squares indicate a time period where the unit is in automatic bypass mode i.e. the unit will monitor the temperatures and open or close the bypass accordingly. White squares (blank spaces) indicate a time block where the heat exchanger bypass will be permanently set to operate and divert air around the heat exchanger regardless of the measured and set temperatures.

Each of the programmes can be *edited* to create bespoke programmes as follows:

From the home screen, press "**PROG**"

Use the "+" and "-" buttons to select the programme number (Factory default is P9)

Press "**PROG**". The programme number will stop flashing and the first block on the timeline at the bottom of the screen will begin to flash.

Select the day to be edited by pressing "**DAY**" until the correct day is displayed along the top of the screen (1 – Monday, 2 – Tuesday etc.)

To add a 30 minute temperature controlled bypass block (a black square) to the timeline, ensure that the word "**BYPASS**" is displayed on the screen by pressing "**BYPASS**".

Press “**SET**” to record or “**ESC**” to discard the settings and return to the home screen

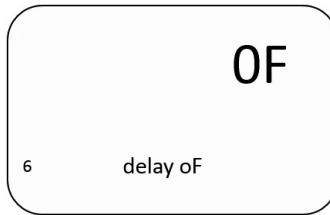

5.10 Setting the automatic heat exchanger bypass operating temperature (for activation see 5.4)

From the home screen, press “**TEMP**” as required to move to menu ‘T3’

*T3 is the target indoor temperature setting at which the heat exchanger bypass mechanism operates to allow the extract air to bypass the heat exchanger and is adjustable between +15°C and +25°C (Factory default 20°C)*

Use the “+” or “-” buttons to set the operating temperature in steps of 1°C

Press “**SET**” to record or “**ESC**” to discard the settings and return to the home screen



5.11 Setting the optional duct-heater operating temperature (°C)

From the home screen, press “**TEMP**” as required to move to menu ‘T4’

T4 is the outdoor temperature setting at which an **optional** intake air duct-heater switch can be activated and is adjustable between +5°C and +12°C (Factory default 10°C)

Use the “+” or “-” buttons to set the activation temperature in steps of 1°C

Press “**SET**” to record or “**ESC**” to discard the settings and return to the home screen



**2.3 Fitting the Domus 297 dry-trap and condensate drain kit**

2.3.1 Using a small amount of solvent weld suitable for ABS pipe fittings (not supplied), attach the threaded socket to the pre-drilled condensate outlet spigot. **Important:** follow the health and safety and user instructions supplied with the solvent weld. This is particularly important when working in confined spaces

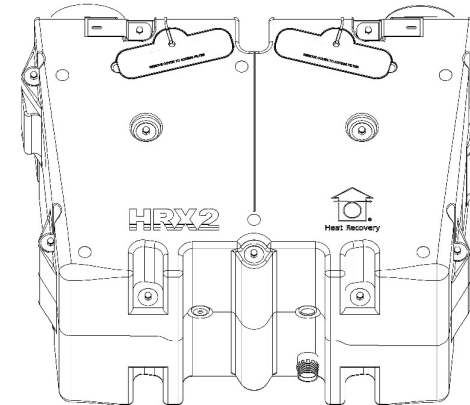

2.3.2 When the threaded socket is secure, fit and hand-tighten the threaded elbow or alternatively the threaded straight adapter, making sure that the rubber seal washer is seated correctly. Gently push the waterless trap onto the elbow stem. **Important:** check that the arrows printed on the trap point away from the HRX2D appliance (in the direction of flow) and prior to fitting, ensure that the waterless trap operates correctly by running a trickle of water from a tap through the trap in the direction of the arrows

2.3.3 Using the remainder of the kit items complete the condensate drain-system to suit the dwelling layout. **Important:** the drain must incorporate a continuous fall of at least 0.5° (9mm in every 1000mm) to the nearest waste water network

2.3.4 The condensate drain system should be adequately supported and suitably insulated if it passes through unheated spaces and voids (e.g. loft spaces) to prevent freezing

**2.4 Ducting guidelines**

2.4.1 Please refer to the design drawings for the proposed ducting layout

2.4.2 Four 204x60mm sockets are provided for connecting the ducting. Ductwork should be securely connected to the sockets using **Domus DDSEAL** acrylic sealant; failure to do this will cause unnecessary air leakage and impair performance. Ducting must be connected to all four sockets in accordance with the configuration shown on page 7 (see 2.2.6)

- 2.4.3 Where ducting passes through unheated areas and voids (e.g. loft spaces) it must be insulated using **Domus Thermal** duct insulation in order to comply with The Building Regulations. Additionally, both ducts connecting the HRX2D to outside must be insulated with an additional continuous vapour barrier to avoid condensation forming on the outside of the ducts
- 2.4.4 Alternative proprietary duct insulation may be used provided it complies with the 2010 Domestic Ventilation Compliance Guide
- 2.4.5 When passing through a fire-stopping wall or fire-compartment wall, **Domus FireBrake** intumescent duct connectors should be used in order to maintain the integrity of fire-stopping walls in accordance with Approved Document B of the Building Regulations
- 2.4.6 Alternative proprietary fire-stopping methods may be employed provided they comply with Approved Document B of the Building Regulations
- 2.4.7 Rigid ducting – install using the least number of fittings to minimise resistance to airflow. All duct runs should be as short and as straight as possible for maximum performance with adequate support
- 2.4.8 Flexible ducting – ensure flexible ducting lengths are kept to a maximum of 300mm and ducting is pulled taut so that it is smooth and straight. Mechanically fix flexible ducts using **Domus 125-5** hose clips and tape seal using **Domus 50TP45** duct tape or any good quality proprietary duct tape for added air-tightness
- 2.4.9 The fresh supply air must be drawn in from the exterior of the property. If drawn through a wall, a **Domus 905** airbrick should be fitted. If drawn in through a pitched roof a **Domus 4411/4411T** universal roof terminal should be fitted or a proprietary roof terminal designed for mechanical ventilation with a free area of at least 10,000mm<sup>2</sup>
- 2.4.10 The stale extract air must be expelled to the exterior of the property. If expelled through a wall, a **Domus 905** airbrick should be fitted. If expelled through a pitched roof a **Domus 4411/4411T** universal roof terminal should be fitted or a proprietary roof terminal designed for mechanical ventilation with a free area of at least 10,000mm<sup>2</sup>
- 2.4.11 It is an industry recommendation (TR35) that the fresh supply and stale exhaust external inlets and outlets should be fitted at least 2m apart to avoid recirculation of stale exhaust air
- 2.4.12 Further details regarding duct installation can be found in the 2010 Domestic Ventilation Compliance Guide.

Press “**SET**” to record or “**ESC**” to discard the settings and return to the home screen

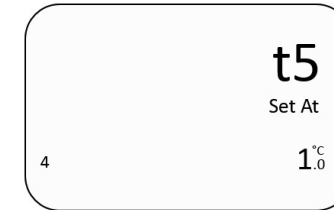

5.8 Delay-on timer activation/deactivation

From the home screen, press and hold “**SET**” and “**COPY**” simultaneously for 3 seconds

Press “**COPY**” once to move to ‘Menu 5’ ‘Delay-on setting’

*The Delay-on setting provides a 3 minute delay before Boost speed is engaged*

Use the “+” or “-” button to set to ‘on’ or ‘off’

Note: The Delay-on function will always be overridden by automatic humidity sensing

Press “**SET**” to record or “**ESC**” to discard the settings and return to the home screen



5.9 Delay-off timer activation/deactivation

From the home screen, press and hold “**SET**” and “**COPY**” simultaneously for 3 seconds

Press “**COPY**” once to move to ‘Menu 6’ ‘Delay-off setting’

*The Delay-off setting provides an adjustable run-on timer when Boost speed is engaged – adjustable between 5 and 30 minutes or ‘off’*

Use the “+” or “-” button to set the desired run-on time in 1 minute steps (Factory default is off)

5.5 Automatic humidity controlled boost activation/inactivation (for adjustment see 5.12)

From the home screen, press and hold **"SET"** and **"COPY"** simultaneously for 3 seconds

Press **"COPY"** as required to move to 'Menu 7' 'IhUn'

Use the **"+"** or **"-"** button to set to 'on' or 'off' (OF) as required

Press **"SET"** to record or **"ESC"** to discard the settings and return to the home screen

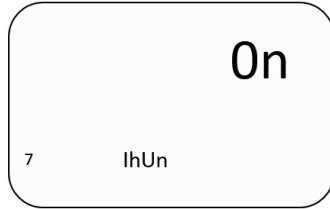

5.6 Filter reminder adjustment/inactivation

From the home screen, press and hold **"SET"** and **"COPY"** simultaneously for 3 seconds

Press **"COPY"** as required to move to 'Menu 1' 'Filter'

Use the **"+"** or **"-"** buttons to change the time delay in steps of 50 hours as required or 'off'.

Note: The filter check reminder is factory set at the maximum of 3000 hours (approx. 4months - recommended). During adjustment, when this maximum has been reached, the 'off' option can be accessed.

Press **"SET"** to record or **"ESC"** to discard the settings and return to the home screen

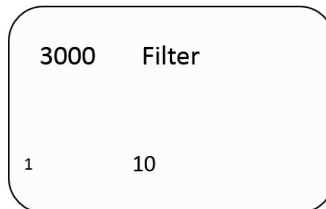

5.7 Frost protection trigger temperature adjustment

From the home screen, press and hold **"SET"** and **"COPY"** simultaneously for 3 seconds

Press **"COPY"** as required to move to 'Menu 4' 'T5'

*Menu T5 sets the frost protection trigger temperature between -15°C and +5°C (Factory default +1°C)*

Use the **"+"** or **"-"** buttons to set the trigger temperature in steps of 1°C

3.0 Electrical

3.1 Overview

3.1.1 **WARNING: This appliance must be earthed.**

3.1.2 **Important: All wiring must conform to the latest edition of BS7671: IEE Wiring Regulations.**

3.1.3 **Important: The electrical installation must be carried out by a qualified electrician.**

3.1.4 This appliance is suitable for 230V 50Hz single phase supply only, fused at 3 Amps.

3.1.5 A double-pole switch having a minimum contact separation of 3mm must be used to provide isolation for the appliance.

3.1.6 External wiring (1.5mm<sup>2</sup> max.) and isolators to be supplied by others.

3.1.7 A 4m length of 4-core signal cable is supplied with the unit to connect the wiring centre to the user interface.

### Wiring centre pcb layout and connections

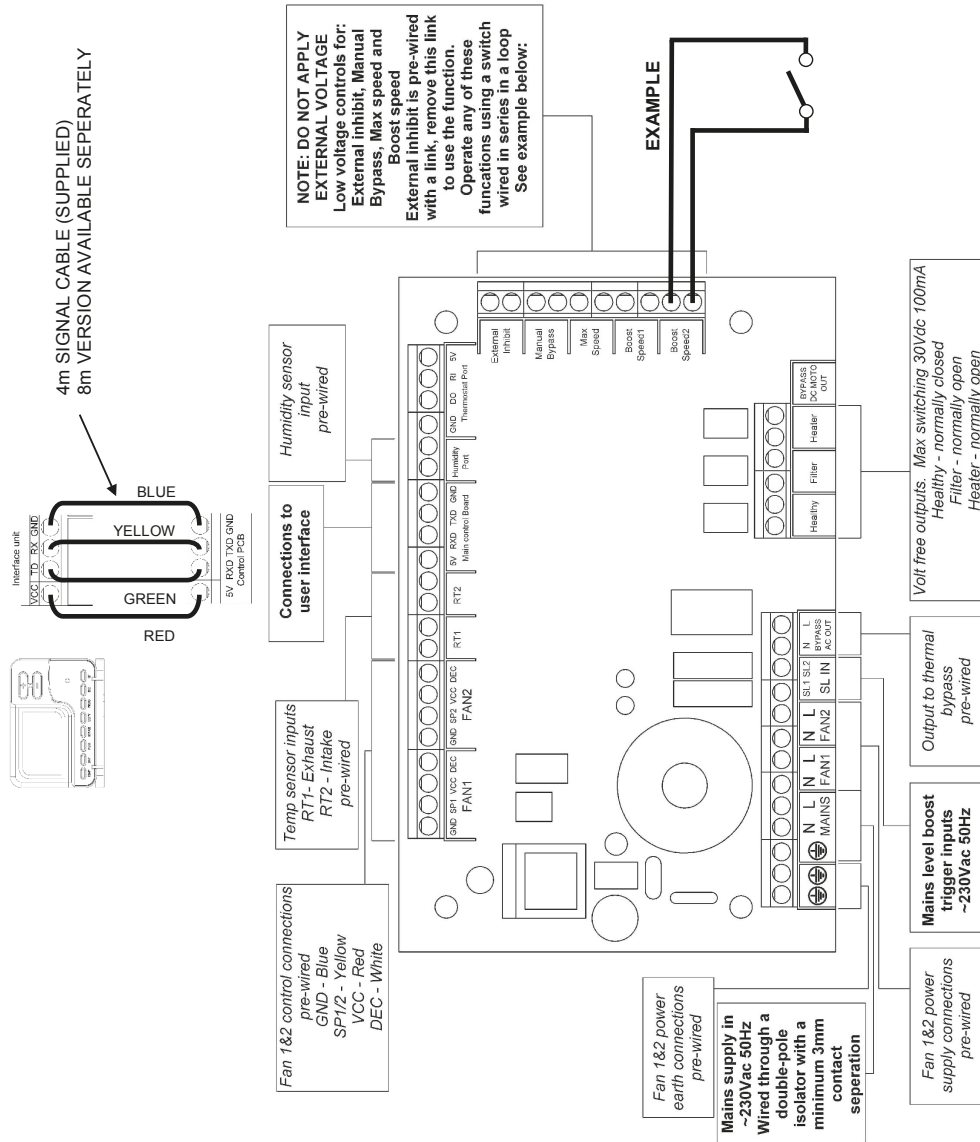

Repeat the steps above for:

Fan 2 Boost (Supply/Intake fan) (Factory default speed is 50%)

Fan 1 Low (Extract/Exhaust fan) (Factory default speed is 20%)



Fan 2 Low (Supply/Intake fan) (Factory default speed is 20%)

'Max' speed can be set to a maximum of 99% (Factory default 80%)

**Note:** Low speed cannot be set higher than Boost speed and Boost speed cannot be set higher than Max speed

Press **"SET"** to record or **"ESC"** to discard the settings and return to the home screen

#### 5.4 Automatic heat exchanger bypass activation/inactivation (for adjustment see 5.10)

From the home screen, press and hold **"SET"** and **"COPY"** simultaneously for 3 seconds

Press **"COPY"** as required to move to 'Menu 3' 'Bypass tEnp'

Use the **"+"** or **"-"** button to set to 'on' or 'off' (OF) as required

Press **"SET"** to record or **"ESC"** to discard the settings and return to the home screen

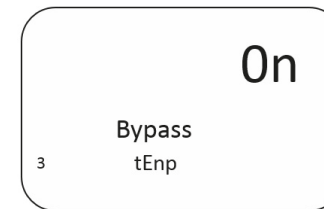

## 5.2 Pre-commissioning

The following steps inhibit automatic functions that could affect the commissioning process and need to be carried out prior to commissioning:

Set the time and date – see 1

From the home screen, press “**PROG**”

Use the “+” and “-” buttons to set the programme number to ‘P9’ (Factory default is P9)

Press “**SET**”

From the home screen, press and hold “**SET**” and “**COPY**” simultaneously for 3 seconds

*This action allows access to the ‘Installer’ programming level (opens at menu 1)*

Press “**COPY**” twice to move to ‘Menu 3’ ‘Bypass tEnp’

Use the “+” or “-” button to set to ‘off’ (OF)

*This action inhibits the automatic bypass operation*

Press “**COPY**” four times to move to ‘Menu 7’ ‘lhuN’

Use the “+” or “-” button to set to ‘off’ (OF)

*This action inhibits the automatic humidity controlled boost operation*

Press “**SET**” to return to the home menu

## 5.3 Commissioning (see also section 4.0 Ventilation Commissioning)

Use the “+” or “-” button to set speed function to ‘Boost’

From the home screen, press and hold “**SET**” and “**COPY**” simultaneously for 3 seconds to open the installer level

Press “**COPY**” once to move to ‘Menu 2’ ‘Fan 1 Low’

Press “**PROG**” once to ‘Fan 1 Boost’ (Extract/Exhaust fan)

Use the “+” or “-” button to set the desired speed (Factory default speed is 50%)

**Note:** The installer level access will time out after 1 minute of inactivity but will record any changes made to the settings

Press “**SET**” to **record** the settings and return to the home screen

Press “**ESC**” to **discard** the settings and return to the home screen

## 4.0 Commissioning

### 4.1 Overview

#### 4.1.1 **IMPORTANT: Ensure that the protective covers have been removed from the filters**

4.1.2 When the wiring connections have been checked, switch on the mains supply and check that the system is operating correctly. See also 5.0 User interface

4.1.3 Airflow rates will need to be set at each room’s air-valve in accordance with the 2010 Domestic Ventilation Compliance Guide to balance the system. Airflow measurements should be performed using a calibrated airflow measuring device. The most common method uses a vane anemometer, placed in a hood which completely covers the air-valve to measure the extract or supply airflow rate. The instrument should be calibrated annually by returning the instrument to a UKAS accredited calibration centre and be capable of achieving an accuracy of  $\pm 5\%$

4.1.4 Each room airflow rate will need to be recorded on an Inspection Checklist and Airflow Measurement Test Sheet. A completed copy must accompany these instructions and be handed over to the dwelling owner upon completion of the installation

### 4.2 System balancing

- Ensure that the pre-commissioning checks have been carried out and that frost protection is not engaged
- Fully open all of the air-valves
- Switch the system to boost using the user interface
- Close all internal and external doors and windows
- Measure the total air volume of the extract valves (wet rooms)
- Using the user interface control, adjust the ‘boost’ speed to achieve the total design extract boost rate
- Adjust individual wet room air-valves to achieve the individual room design extract rates
- Switch the system to low using the user interface
- Measure the total air volume of the supply valves (habitable rooms)
- Using the user interface control, adjust the ‘low’ speed to achieve the total design supply rate
- Adjust individual habitable room air-valves to achieve the individual room design supply rates
- Double check all of the valve flow rates and record the readings
- Using the lock nuts fitted to the air-valves, lock in position

**5.0 User control interface operation**

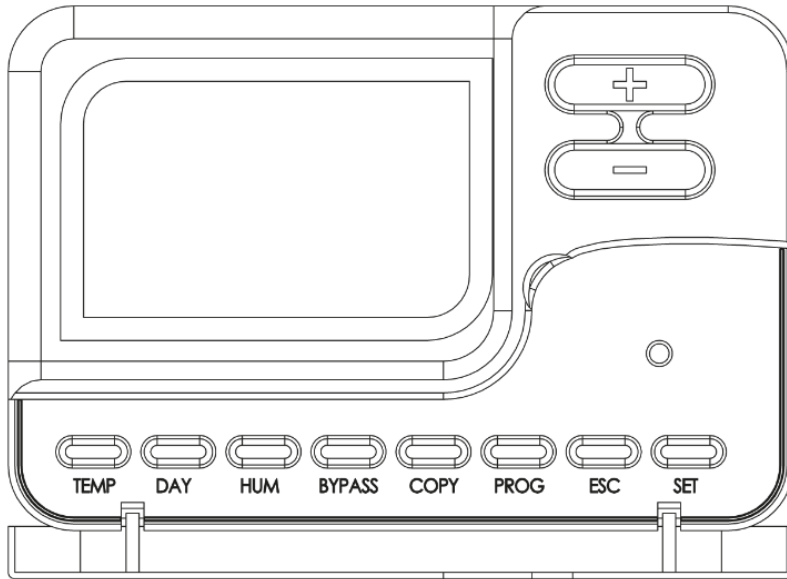

**User control interface  
front view**

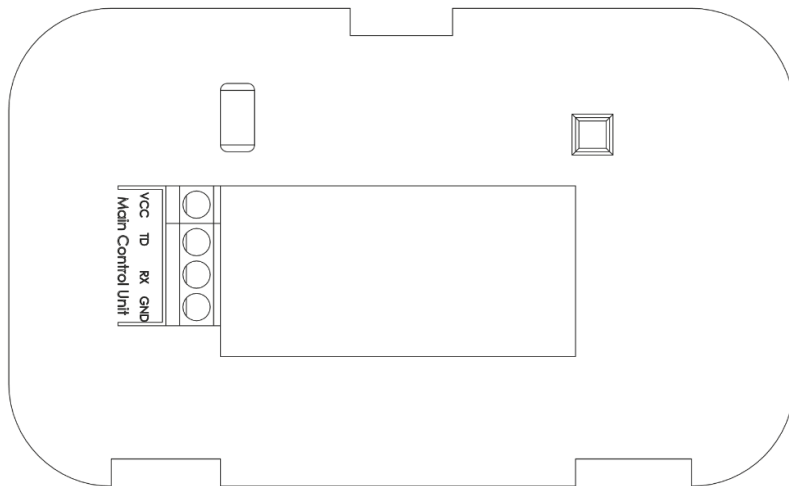

**User control interface  
back view**

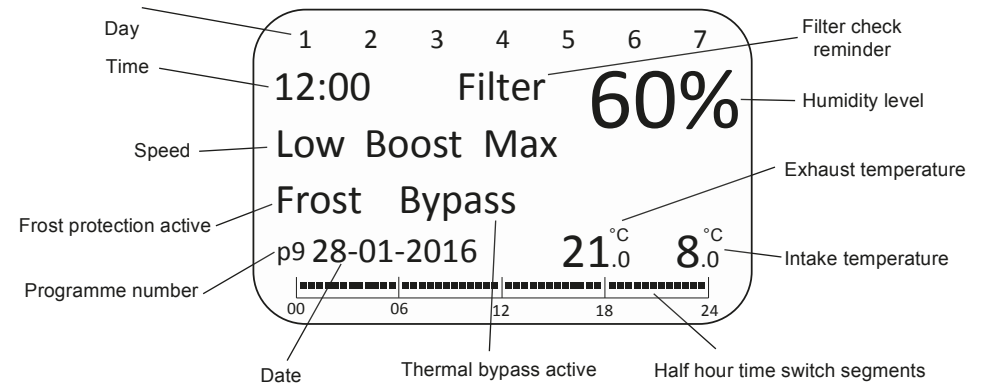

**5.1 Time and date setting (this action is required when power is first applied to the system):**

From the home screen, Press **"DAY"**. The hour text will flash

Use the **"+"** and **"-"** buttons to set the hour

Press **"DAY"**. The minute text will flash

Use the **"+"** and **"-"** buttons to set the minute

Press **"DAY"**. The day will flash

Use the **"+"** and **"-"** buttons to set the day

Press **"DAY"**. The month will flash

Use the **"+"** and **"-"** buttons to set the month

Press **"DAY"**. The year will flash

Use the **"+"** and **"-"** buttons to set the year

Press **"DAY"**. 12/24 will flash

Use the **"+"** and **"-"** buttons to set 12 or 24 hour clock format

Press **"DAY"** to confirm and return to home screen